

# PROFI E-Tec

12

models



fischer**technik**





**Inhalt**  
**Contents**  
**Contenu**

**Inhoud**  
**Contenido**  
**Conteúdo**

Einzelteilübersicht / Spare parts list / Liste des pièces détachées / Onderdelenoverzicht / Lista da peças / Resumo de peça individual

2

Montagehilfen und Hinweise / Assembly aids and instructions / Aides de montage et instructions /  
Montagehulpmiddelen en aanwijzingen / Ayudas de montaje e instrucciones / Montagens e indicações

3

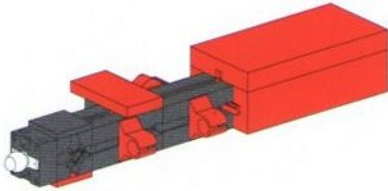

Taschenlampe / Torch / Lampe de poche /  
Zaklamp / Linterna / Lâmpada de mão

5

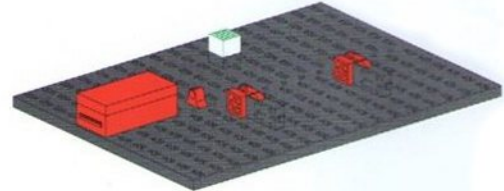

UND-/ ODER-Schaltung / AND-OR circuit / Circuit ET/OU /  
EN/OF-schakeling / Circuito Y/O / Conexão E/OU

11

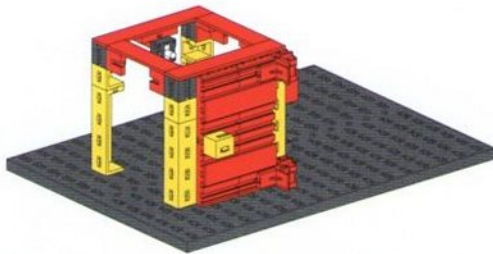

Kühlschrankbeleuchtung / Refrigerator with interior lighting / Réfrigérateur  
avec éclairage intérieur / Koelkast met binnenverlichting / Frigorífico con  
iluminación interior / Frigorífico com iluminação interior

6

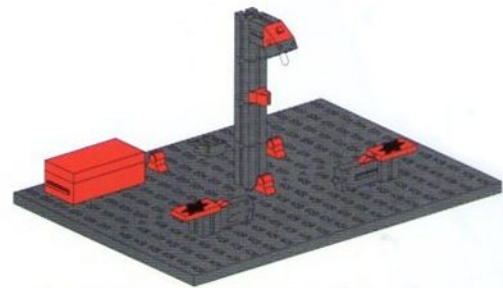

Treppenhausbeleuchtung / Staircase lighting / Éclairage de cage  
d'escalier / Trappenhuisverlichting / Iluminación de escalera /  
Iluminação do vão das escadas

12

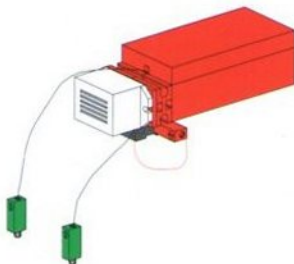

Durchgangsprüfer / Continuity tester /  
Appareil de contrôle de continuité / Doorgangstester /  
Probador de continuidad / Verificador de continuidade

9

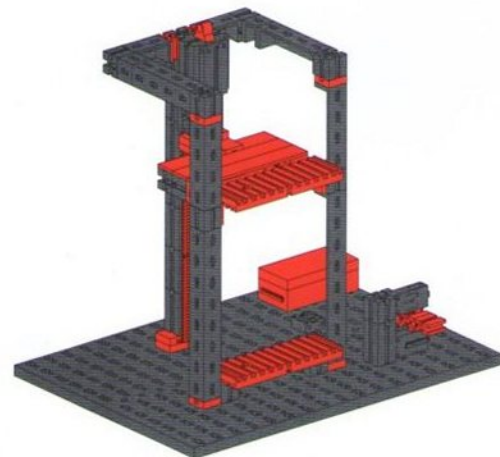

Aufzug / Elevator / Ascenseur / Lift / Ascensor / Elevador

14

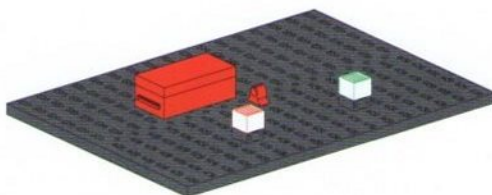

Reihen- und Parallelschaltung / Series and parallel connection /  
Circuit en série et en parallèle / Serie- en parallelschakeling /  
Conexión en serie y en paralelo / Conexão em série e paralela

10

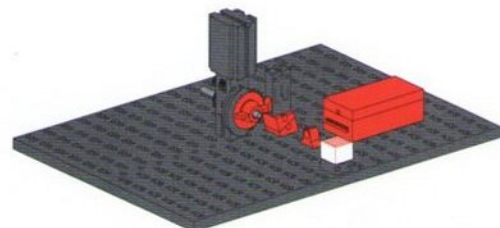

Einfaches Blinklicht / Simple flash light / Feu clignotant simple  
Eenvoudig knipperlicht / Luz intermitente sencilla /  
Lâmpada intermitente

19

**Inhalt**  
**Contents**  
**Contenu**



Turm mit Warnblinklicht / Tower with blinking warning light /  
Tour avec feux de détresse / Toren met knipperlicht / Columna  
con luz de aviso de emergencia / Torre com luz de aviso

20

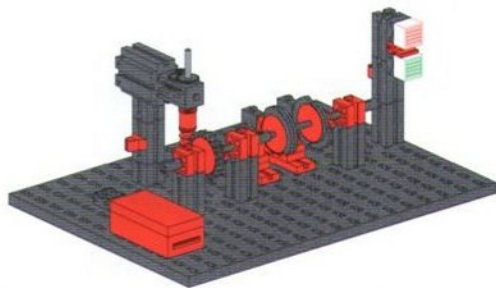

Ampelsteuerung / Traffic light control / Commande des feux de  
signalisation / Regeling van een verkeerslicht / Mando del semáforo /  
Comando de semáforo

24

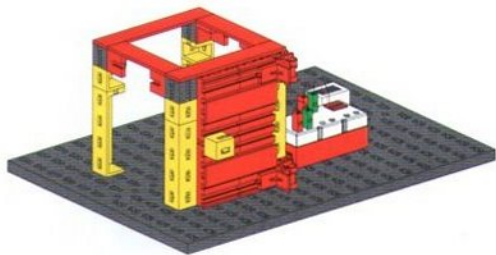

Alarmanlage / Alarm system / Dispositif d'alarme /  
Alarminstallatie / Instalación de alarma / Sistema de alarma

28

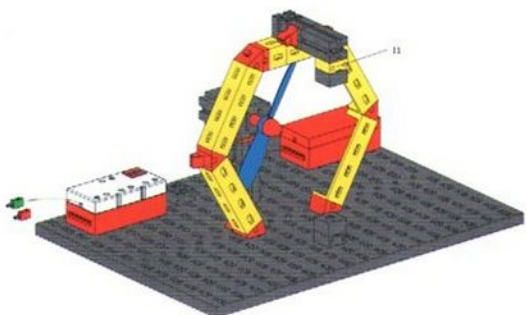

Händetrockner / Hand dryer / Sèche-mains /  
Handdroger / Secamanos / Secador de mãos

31

**Inhoud**  
**Contenido**  
**Conteúdo**

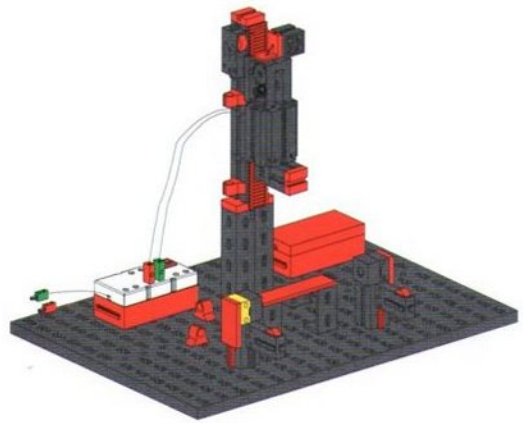

Stanzmaschine / Punching machine / Poinçonneuse /  
Stansmaschine / Punzonadora / Máquina de puncionar

34

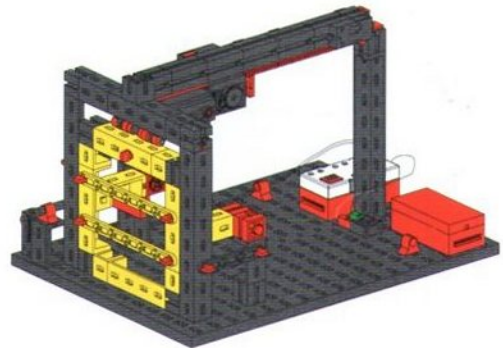

Garagentor / Garage door / Porte de garage / Garagedeur /  
Puerta del garaje / Portão da garagem

38

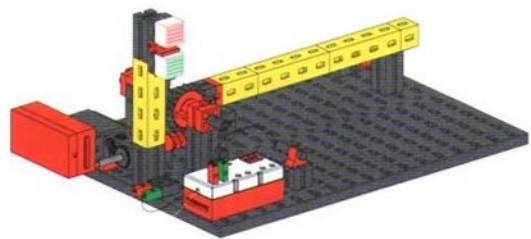

Parkhausschranke / Barrier of a public garage / Barrière de parking /  
Slagboom aan de parkeergarage / Barrera del aparcamiento /  
Barreiras do silo-auto

44



Bausteinspender / Brick dispenser / Distributeur d'éléments de  
construction / Bouwsteenautomaat / Dispensador de elementos /  
Distribuidor do componente

48



**Einzelteilübersicht**  
**Spare parts list**  
**Liste des pièces détachées**

**Onderdelenoverzicht**  
**Lista da piezas**  
**Resumo de peça individual**

	31 010 4x		31 982 4x		35 066 1x		36 559 1x		37 858 1x
	31 011 3x		32 064 4x		35 073 3x		36 819 1x		37 869 2x
	31 016 1x		32 233 1x		35 076 3x		36 913 4x		37 875 1x
	31 021 1x		32 263 1x		35 079 1x		36 920 4x		38 216 4x
	31 033 1x		32 293 1x		35 084 1x		36 921 4x		38 240 4x
	31 058 3x		32 330 2x		35 087 1x		36 950 4x		38 241 4x
	31 060 5x		32 850 1x		35 969 8x		37 034 1x		38 242 1x
	31 061 2x		32 859 2x		36 119 1x		37 237 4x		38 245 2x
	31 063 1x		32 870 2x		36 120 1x		37 238 2x		38 246 2x
	31 078 1x		32 879 11x		36 134 1x		37 272 1x		38 423 4x
	31 336 22x		32 881 10x		36 293 3x		37 351 3x		38 428 5x
	31 337 22x		32 882 4x		36 297 4x		37 468 4x		38 464 4x
	31 360 1x		32 958 1x		36 299 2x		37 636 1x		38 531 2x
	31 426 2x		32 985 1x		36 323 11x		37 679 4x		108 227 1x
	31 436 3x		35 031 3x		36 334 2x		37 681 1x		108 278 1x
	31 848 2x		35 049 2x		36 443 1x		37 727 4x		
	31 915 1x		35 053 5x		36 532 2x		37 783 3x		



**Montagehilfen und Hinweise**  
**Assembly aids and instructions**  
**Aides de montage et instructions**

**Montagehulpmiddelen en aanwijzingen**  
**Ayudas de montaje e instrucciones**  
**Montagens e indicações**

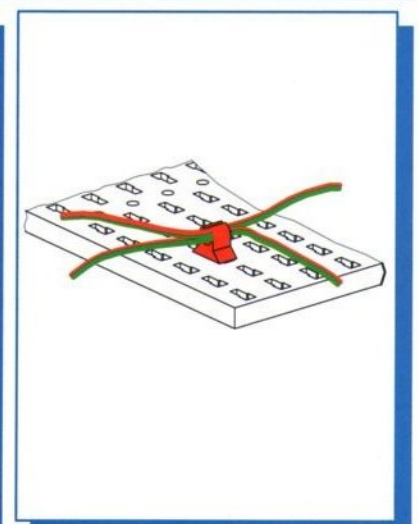
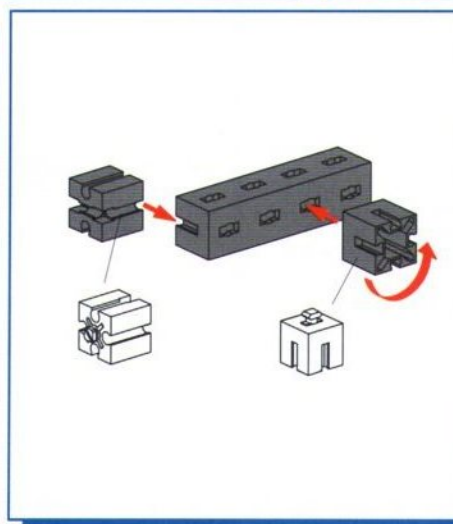
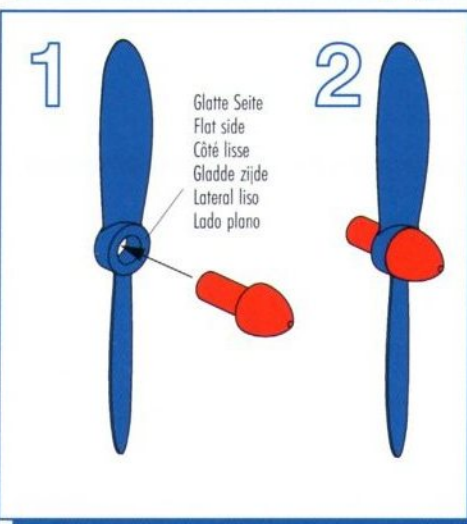
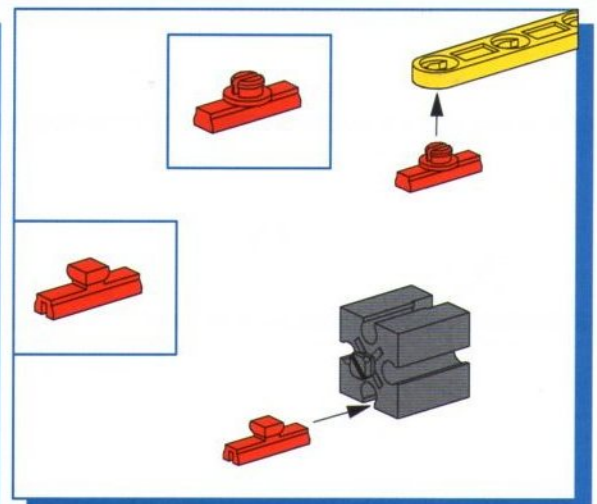
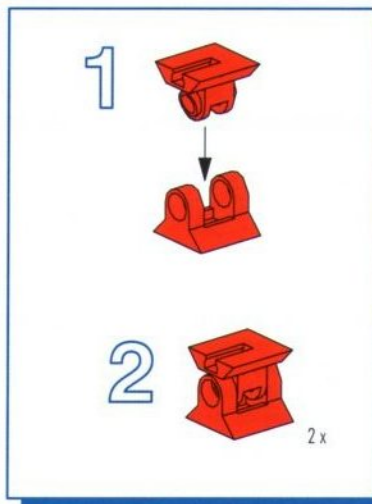
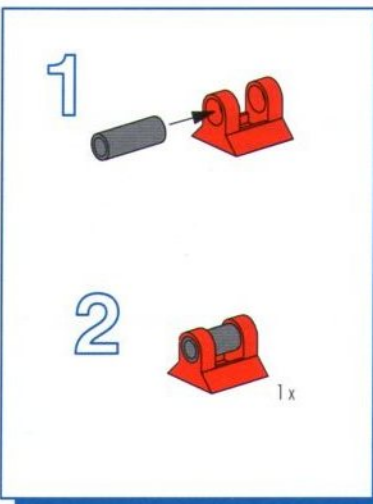
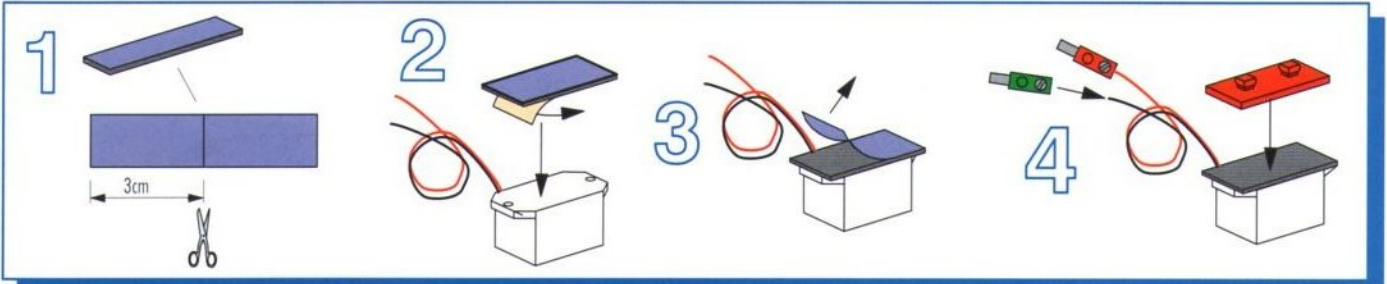
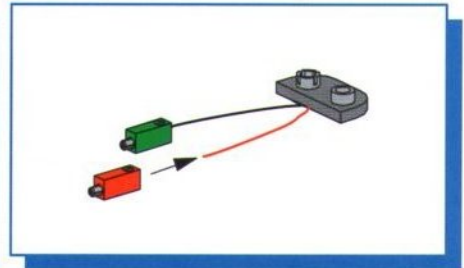
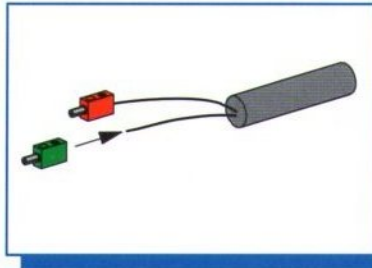
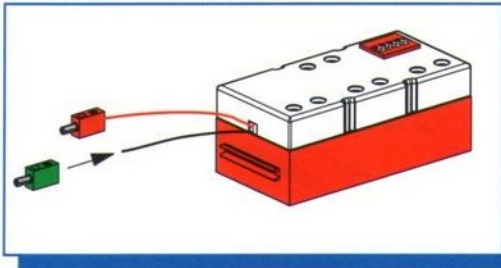

- Alle Einzelteile, insbesondere bewegliche Teile sind falls notwendig zu warten und zu reinigen.
- All components, especially moving parts, should be maintained and cleaned as necessary.
- Toutes les pièces détachées et en particulier les pièces mobiles, sont, si nécessaire, à entretenir et à nettoyer.

- Achtung  
Verletzungsgefahr an Bauteilen mit funktionsbedingten scharfen Kanten und Spitzen!
- Caution  
Be careful not to hurt yourself on components with sharp or pointed edges!
- Attention  
Risque de blessure sur les éléments comportant des arêtes et o pointes vives indispensables au bon fonctionnement!

- Alle onderdelen, vooral de bewegende delen, kunnen, indien noodzakelijk, onderhouden en gereinigd worden.
- Es necesario limpiar y mantener en buen estado todas las diferentes piezas - especialmente las piezas móviles.
- Caso necessário, todas as peças individuais, especialmente peças móveis, tem que ser submetidas à manutenção e ser limpas.

- Let op  
U kunt zich bezeren aan bouwstenen met scherpe randen of punten!
- Attenzione  
Esiste il pericolo di lesione con i pezzi di costruzione che hanno bordi e punte spigolosi necessari per la funzionalità del pezzo!
- Atenção  
Perigo de ferimentos em peças componentes com cantos vivos e pontas obrigatórios para o funcionamento!



# Montagehilfen und Hinweise Assembly aids and instructions Aides de montage et instructions

# Montagehulpmiddelen en aanwijzingen Ayudas de montaje e instrucciones Montagens e indicações

Kabel und Stecker  
Plugs and cables  
Fiches et des câbles

Stekkers en cables  
Enchufes en cables  
Cabos e contatos

1



1 x 10 cm  
4 x 15 cm  
1 x 20 cm  
2 x 25 cm  
1 x 40 cm



2



3

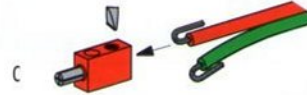
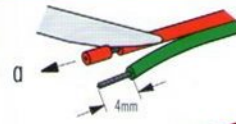

4



1 x 10 cm  
4 x 15 cm  
1 x 20 cm  
2 x 25 cm  
1 x 40 cm

5

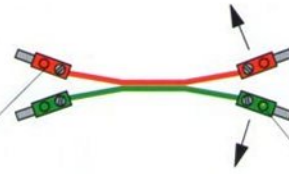

1 x 15 cm

25 cm  
20 cm  
15 cm  
10 cm  
5 cm  
0

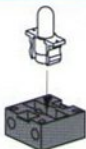

Kugellampe  
Bulb lamp  
Lampe sphérique  
Bolle lamp  
Lâmpada sferica  
Lâmpada esférica



Linsenlampe  
Lens tip lamp  
Ampoule lentille  
Lenslampje  
Lâmpada lenticolare  
Lâmpada de formato lenticular



oder  
or  
ou  
o  
ou



### 1 Batterie 9Volt-Block Alkaline oder 1 NC-Akku 9V

- Leere Akkus zum Laden entnehmen.
- Verbrauchte Batterien dem Sondermüll zuführen.

### 9V rechargeable battery or 9 V alkaline dry cell

- Remove discharged battery and place in charger for recharging.
- Discard spent dry cells at special waste disposal centre.

### pile 9V ou accu 9V

- Pour recharger les accus vides, il faut les sortir et les placer dans le chargeur.
- Jeter les piles usagées dans un conteneur spécial réservé à cet effet.

### alkaline batterije of oplaadbare batterije (9Volt)

- Voor het opladen van batterijen de lege batterijen uit nemen en met behulp van het oplaadapparaat opladen.
- Afleveren gebruikte batterijen bij het klein chemisch afval (KCA).

### pila alcalina bloque de 9 Voltios o acumulador NC de 9 Voltios

- Retirar el acumulador descargado y colocarlo en el cargador
- Retirar las baterias viejas, desechándolas en un depósito de basuras especiales.

### Bateria alcalina de bloco de 9 V ou acumulador NC de 9 V

- Remover os acumuladores vazios para os carregar
- Eliminar as baterias esgotadas como desperdício perigoso

Fototransistor  
Phototransistor  
Fototransistores  
Phototransistor



9V ...

Achtung: Beim Anschluß auf richtige Polung achten. Rot = +  
Caution: Make sure the terminals are connected correctly. Red = +  
Attention: lors du raccordement, veiller à ce que la polarisation soit exacte, rouge = +  
Pas op: let bij het aansluiten op de juiste polariteit, rood = +  
Atención: al conectar, procurar que los polos estén correctamente colocados, roja = +  
Atenção: Por ocasião da conexão atentar para a polaridade correta. Vermelho = +

Batterie ist nicht Inhalt der Packung  
Battery not included  
Batterie non comprise  
De batterij wordt niet meegeleverd  
La batería no está incluida en el suministro  
A bateria não é o conteúdo da embalagem

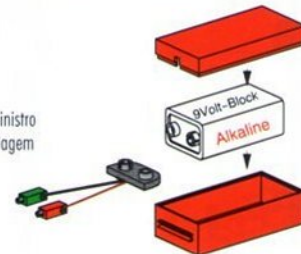

- Alle elektrischen Bauteile (Sensoren, Motoren, Lampen) dürfen ausschließlich an Stromversorgungen von fischertechnik angeschlossen werden (z.B. Energy Set Art.-Nr. 30182; Accu Set Art.-Nr. 34969).
- No electrical components (sensors, motors, lamps) are to be connected to any other power supply than that provided by fischertechnik (e.g. Energy Set, product no. 30182, Accumulator Set, product no. 34969).
- Tous les composants électriques (Capteurs, moteurs, lampes) ne doivent être branchés aux alimentations électriques uniquement que par la société Fischertechnik (par exemple: Set énergie Art.-Nr. 30182, Accu Set Art.-Nr. 34969).
- Alle elektrische componenten (sensoren motoren, lampen) mogen uitsluitend op stroomvoorzieningen van fischertechnik worden aangesloten. (bijv. Energy Set art.nr. 30182, Accu Set art.nr. 34969).
- Todos los componentes eléctricos (sensores, motores, luces) deben conectarse a la alimentación de corriente de la técnica Fischer exclusivamente (p.ej. Energy Set Art.-Nº. 30182, Accu Set Art.-Nº. 34969).
- Todas as peças componentes elétricas (sensores, motores, lâmpadas) só podem ser exclusivamente conectadas em abastecimentos de corrente da Fischertechnik (p.ex. Energy Set Nº de prod. 30182, Accu Set Nº de prod. 34969).



Taschenlampe  
Torch  
Lampe de poche

Zaklamp  
Linterna  
Lâmpada de mão

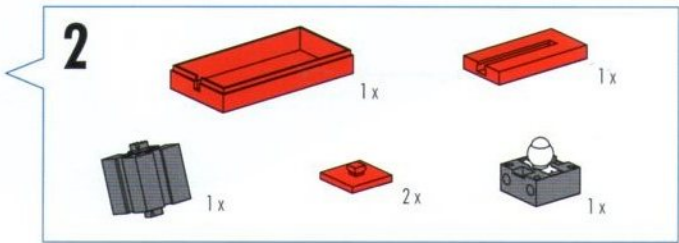
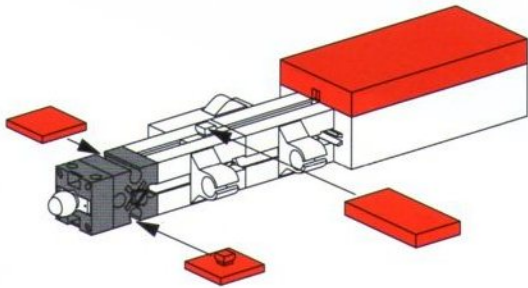
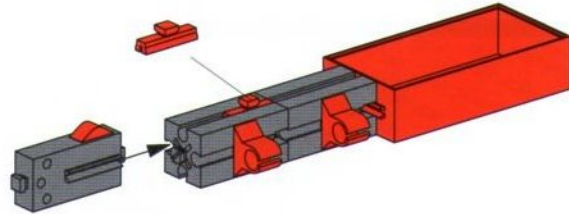
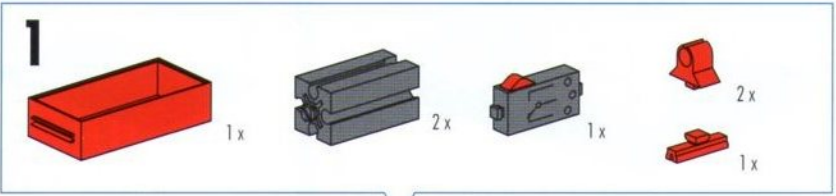
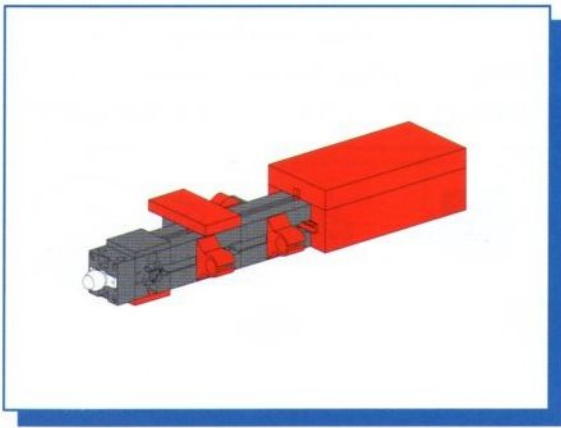

Linsenlampe  
Lens tip lamp  
Ampoule lentille  
Lenslampje  
Lâmpada lenticolare  
Lâmpada de formato lenticular

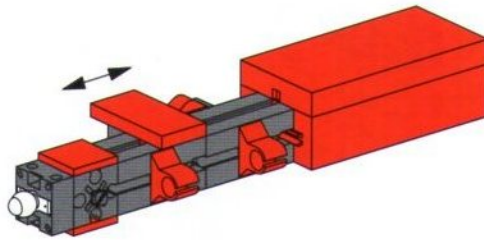

Schaltplan  
Circuit diagram  
Plan électrique

Schakelschema  
Diagrama de circuitos  
Plano elétrico de ligação

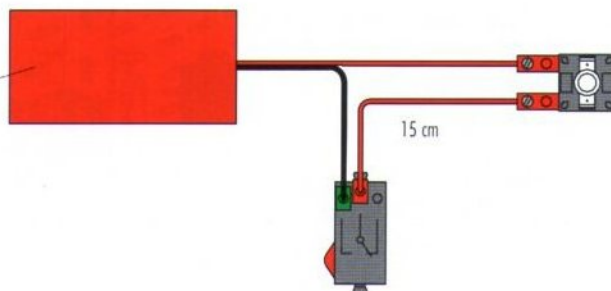
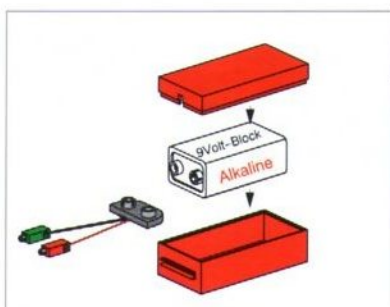



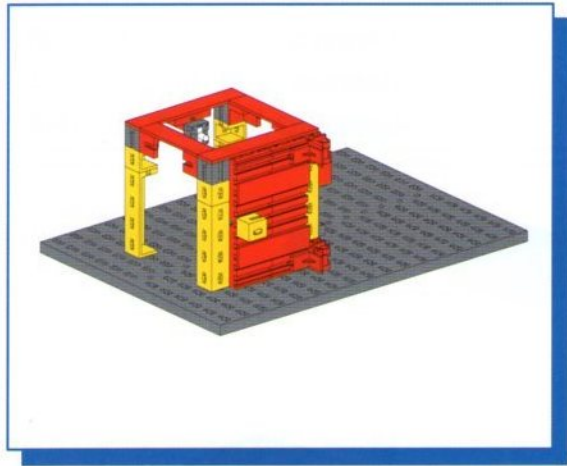

Kühlschrankbeleuchtung  
Refrigerator with interior lighting  
Réfrigérateur avec éclairage intérieur

Koelkast met binnenverlichting  
Frigorífico con iluminación interior  
Frigorífico com iluminação interior

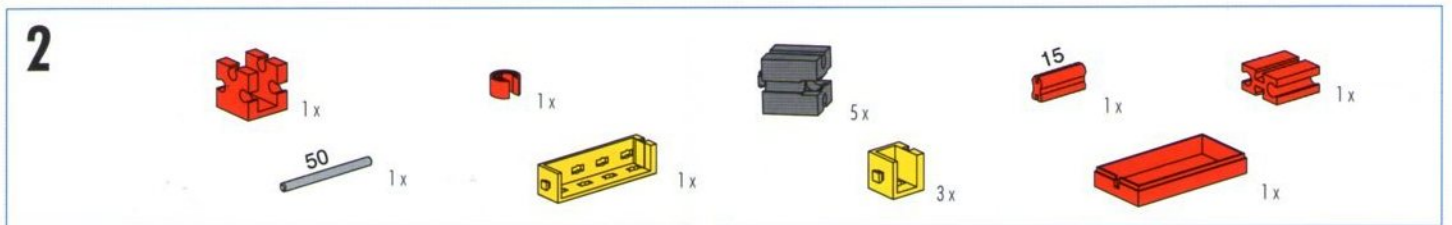
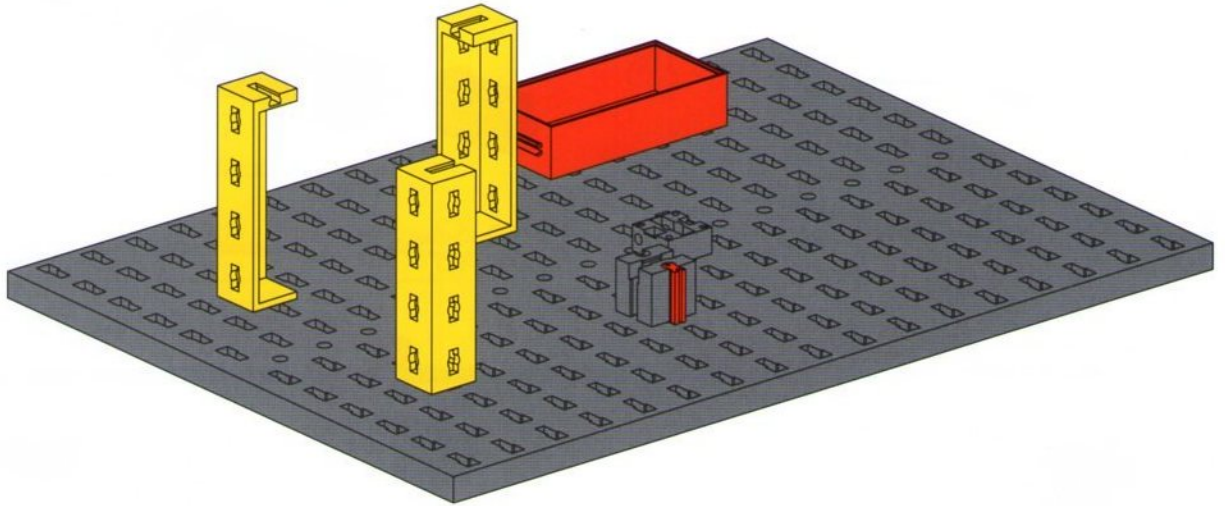
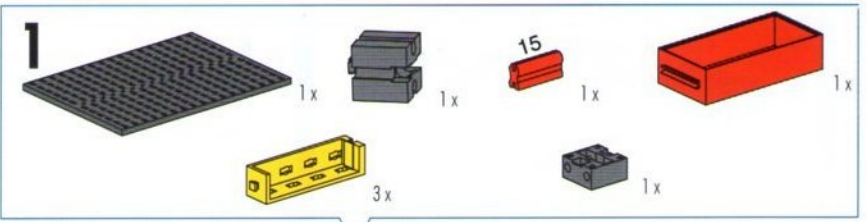

50  
Stahlachse · Steel axle · Essieu en acier ·  
Stalen as · Eje de acero · Eixo de aço

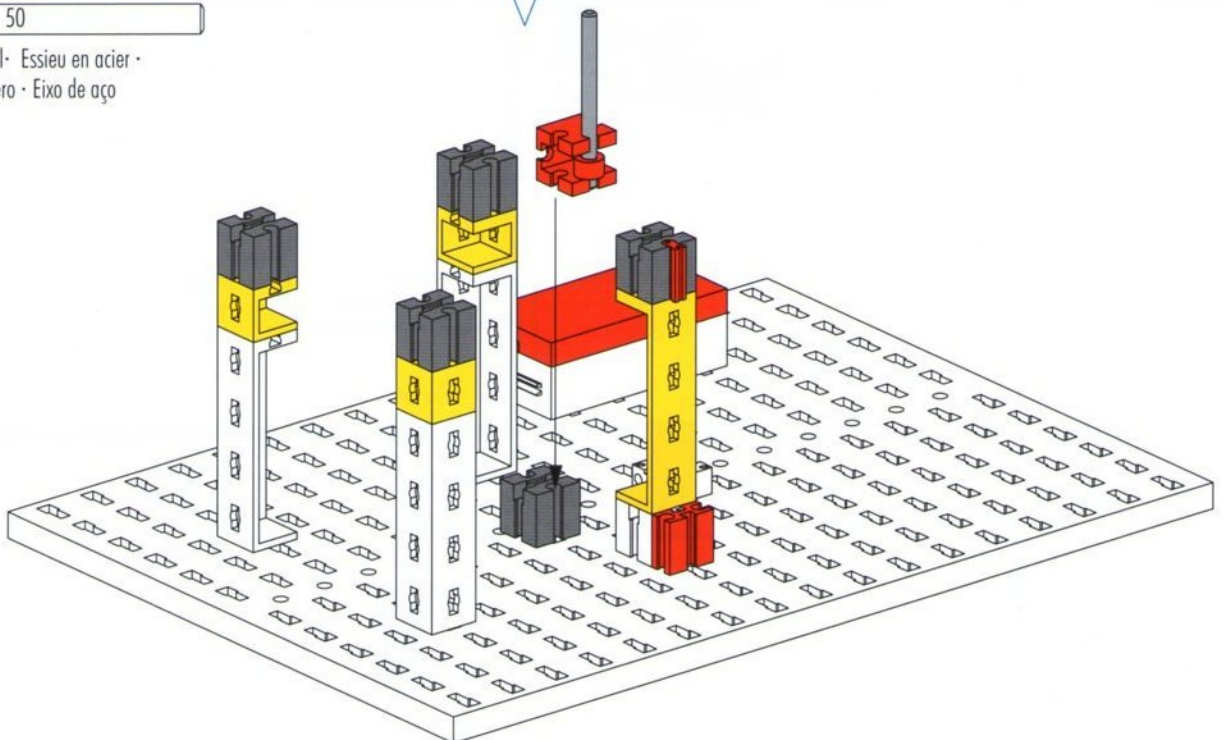



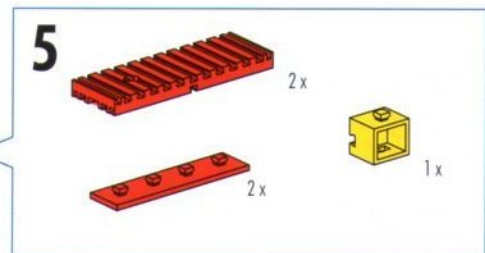
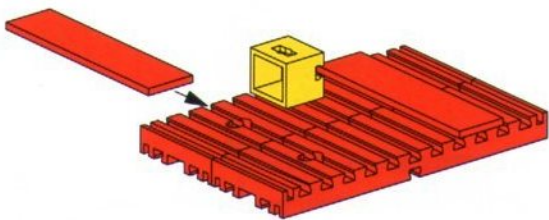
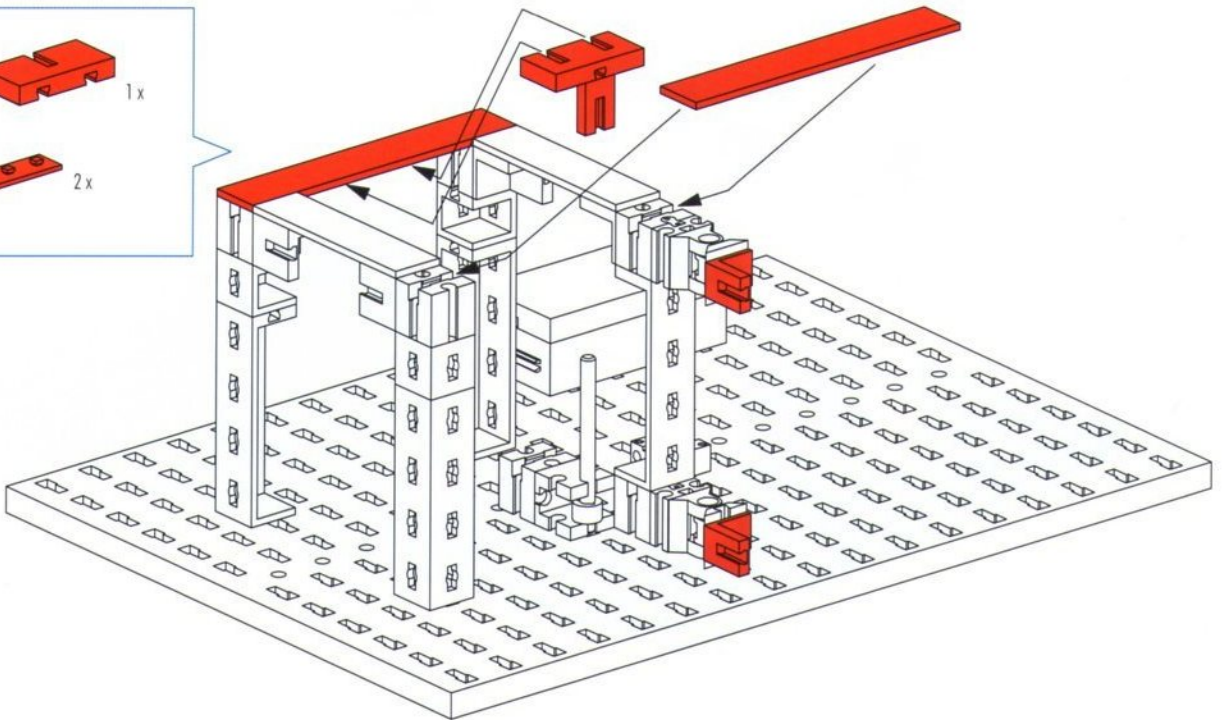
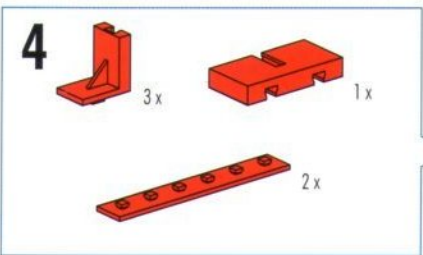
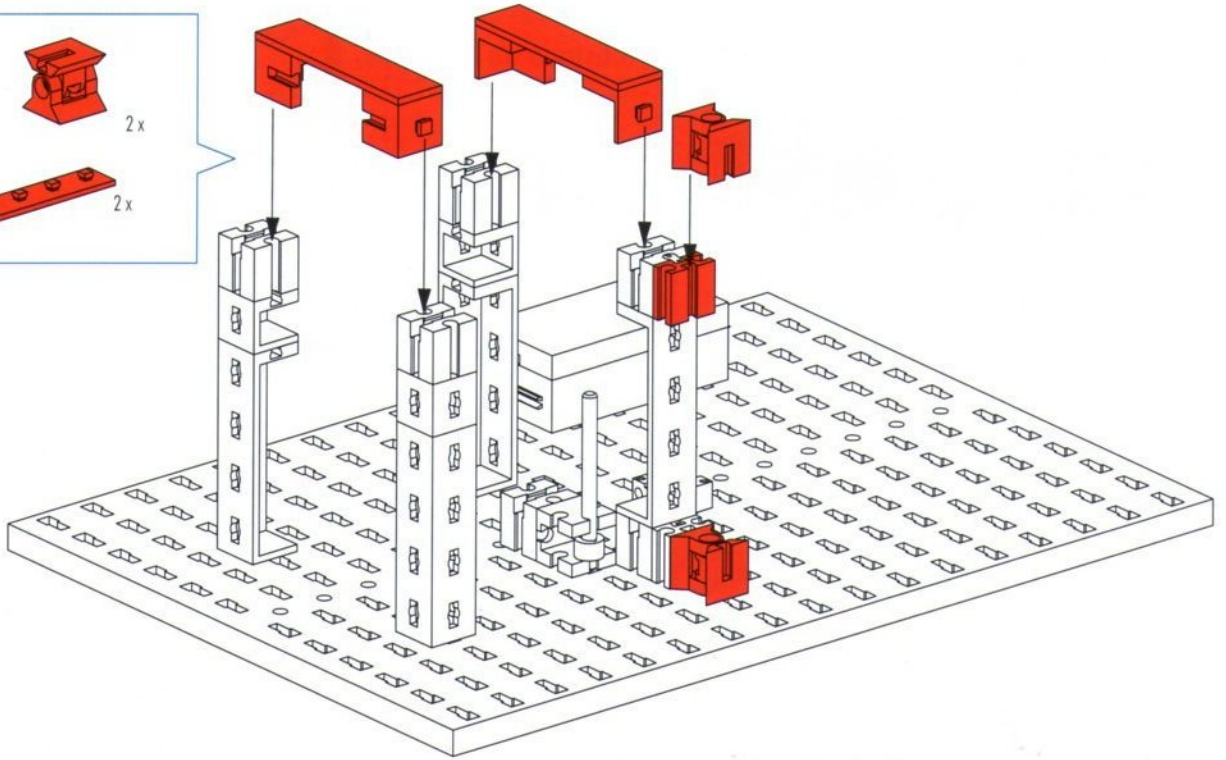
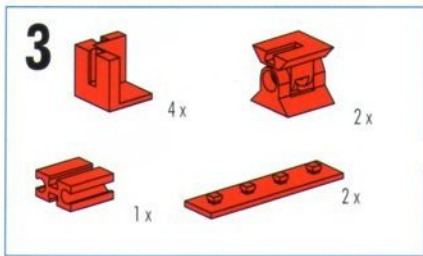







Durchgangsprüfer  
 Continuity tester  
 Appareil de contrôle de continuité

Doorgangstester  
 Probador de continuidad  
 Verificador de continuidade

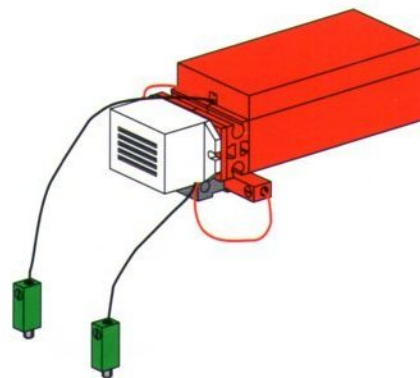
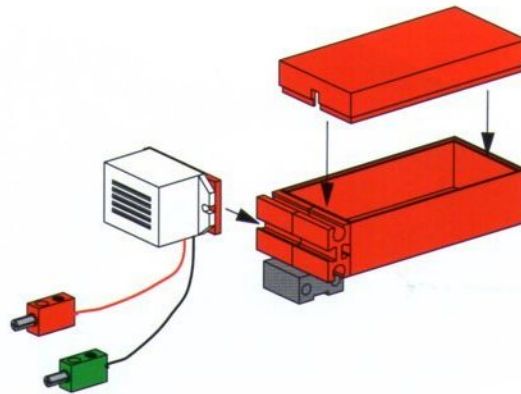
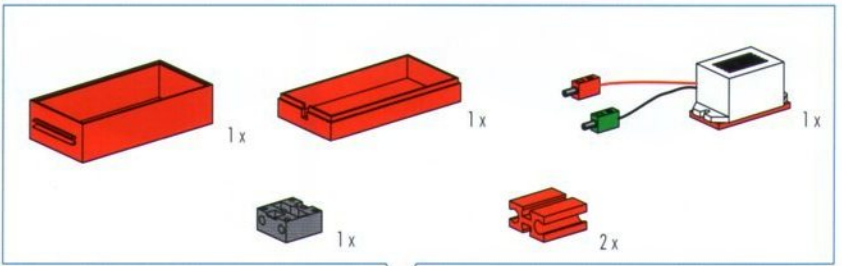
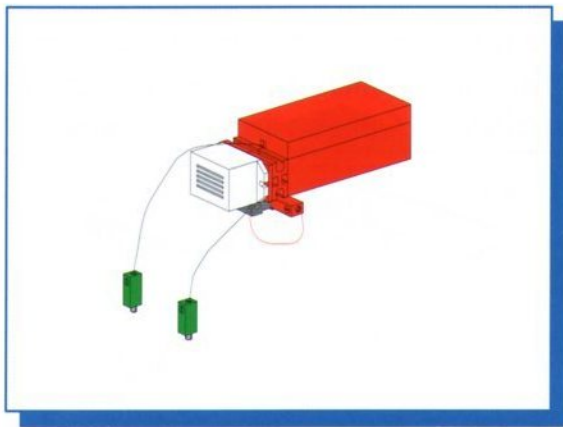

Schaltplan  
 Circuit diagram  
 Plan électrique

Schakelschema  
 Diagrama de circuitos  
 Plano elétrico de ligação

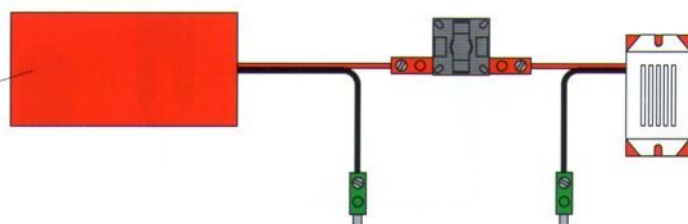
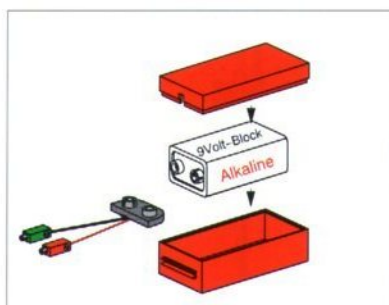



Reihen- und Parallelschaltung  
Series and parallel connection  
Circuit en série et en parallèle

Serie- en parallelschakeling  
Conexión en serie y en paralelo  
Conexão em série e paralela

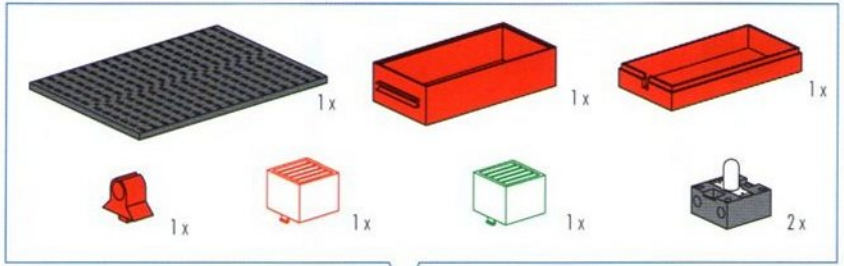

Kugellampe  
Bulb lamp  
Lampe sphérique  
Bolle lamp  
Lâmpada sferica  
Lâmpada esférica

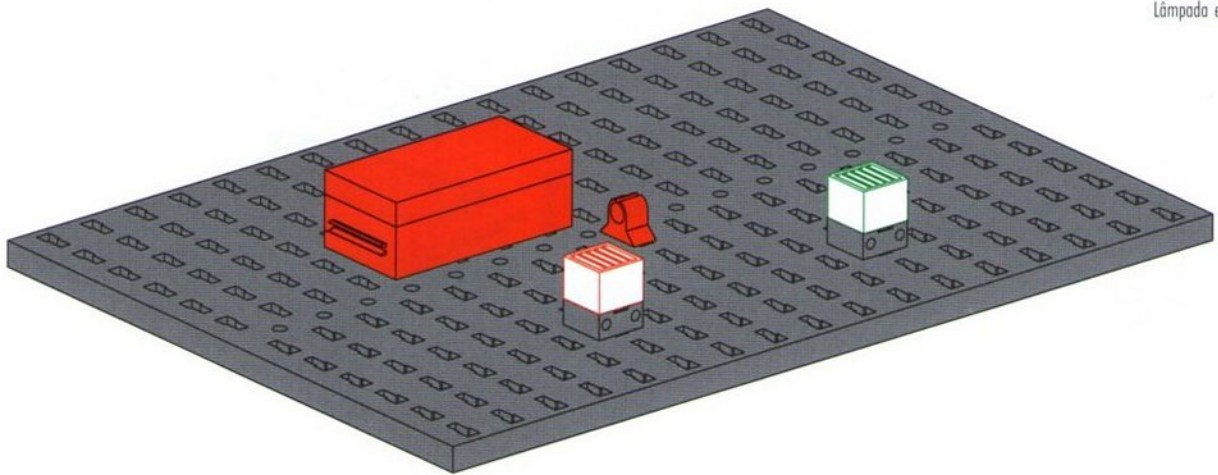

Schaltplan  
Circuit diagram  
Plan électrique

Schakelschema  
Diagrama de circuitos  
Plano elétrico de ligação

Parallelschaltung / Parallel connection / Circuit en parallèle /  
Parallelschakeling / Conexión en paralelo / Conexão paralela

Reihenschaltung / Series connection / Circuit en série /  
Serieschakeling / Conexión en serie / Conexão em série

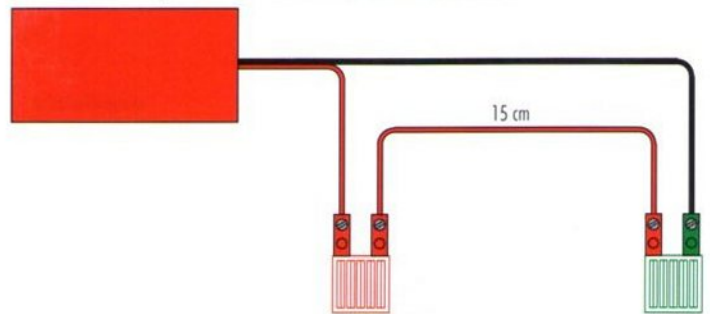
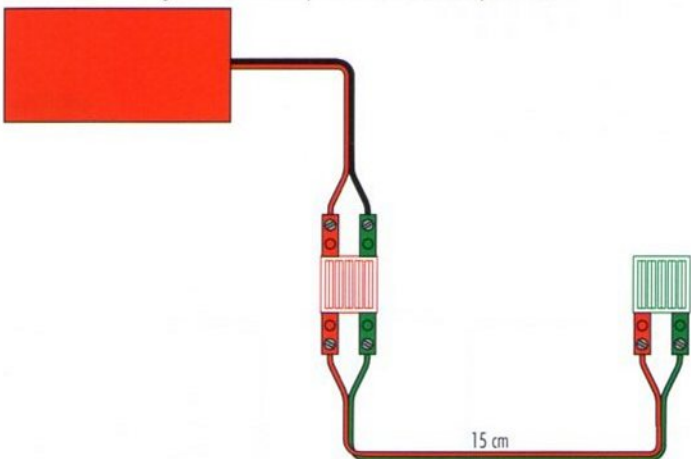



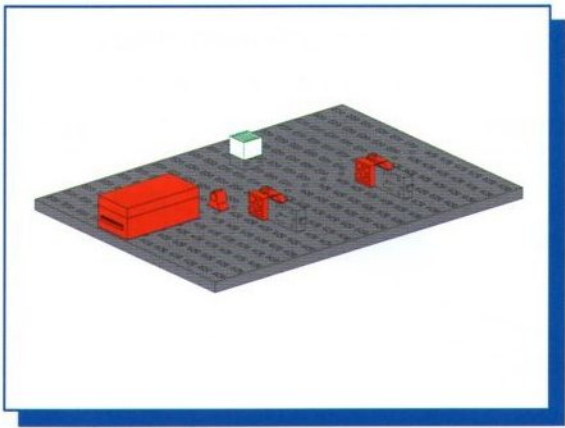

**UND-/ ODER-Schaltung**  
**AND-OR circuit**  
**Circuit ET/OU**

**EN/OF-schakeling**  
**Circuito Y/O**  
**Conexão E/OU**

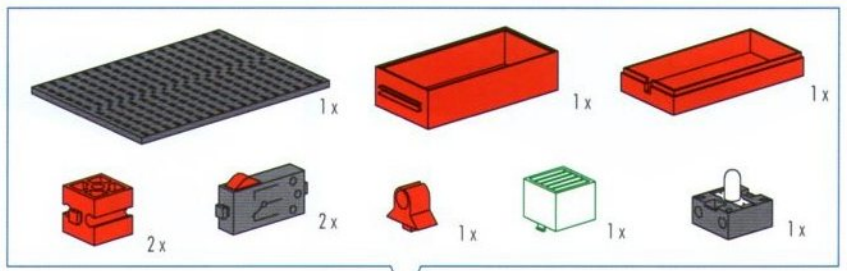

Kugellampe  
 Bulb lamp  
 Lampe sphérique  
 Bola lamp  
 Lâmpada esférica  
 Lâmpada esférica

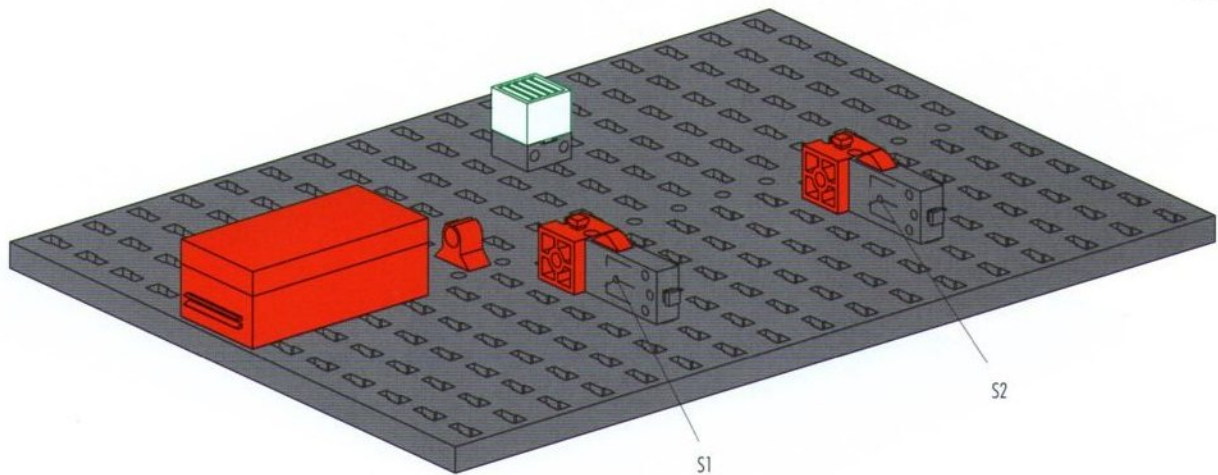

**Schaltplan**  
**Circuit diagram**  
**Plan électrique**

**Schakelschema**  
**Diagrama de circuitos**  
**Plano elétrico de ligação**

**ODER - Schaltung / OR circuit / Circuit OU /**  
**OF-schakeling / Circuito O / Conexão OU**

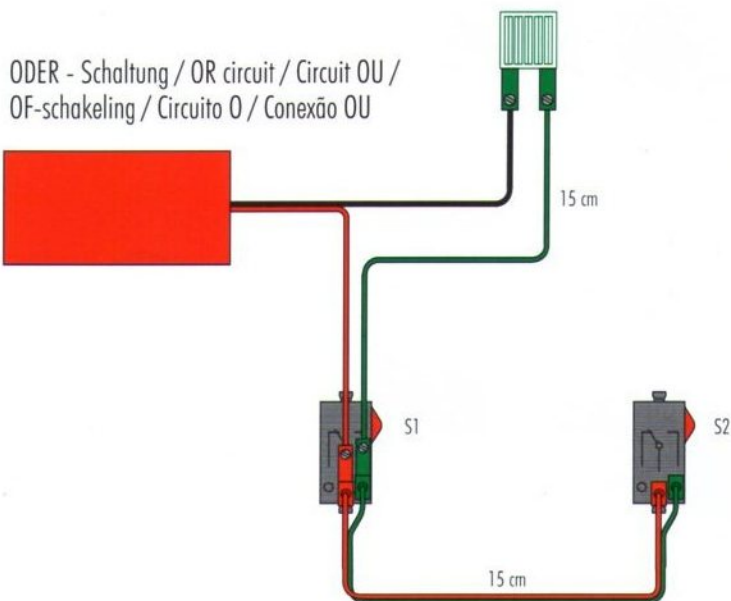

**UND - Schaltung / AND circuit / Circuit ET /**  
**EN-schakeling / Circuito Y / Conexão E**

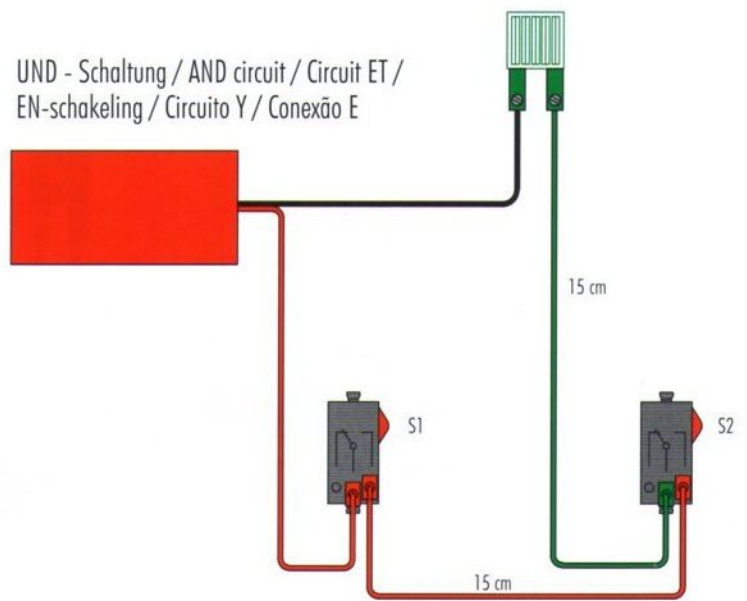

Treppenhausbeleuchtung  
Staircase lighting  
Éclairage de cage d'escalier

Trappenhuisverlichting  
Iluminación de escalera  
Iluminação do vão das escadas

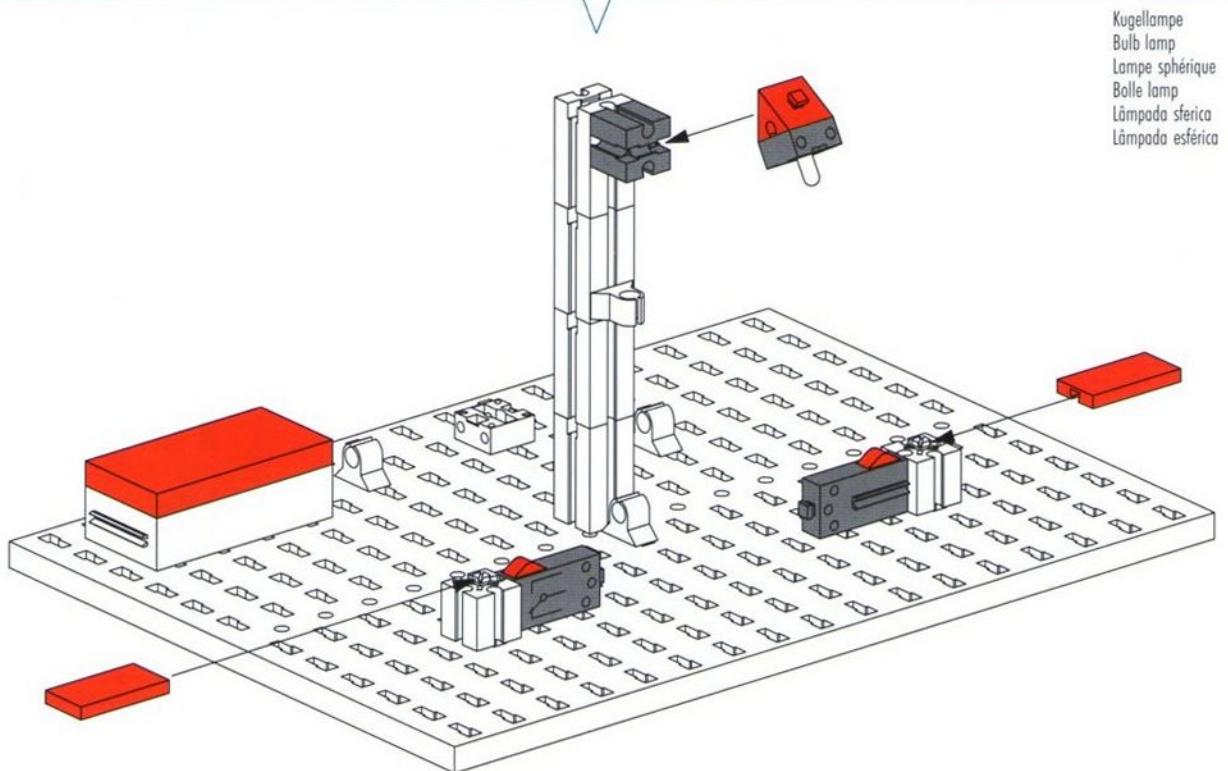
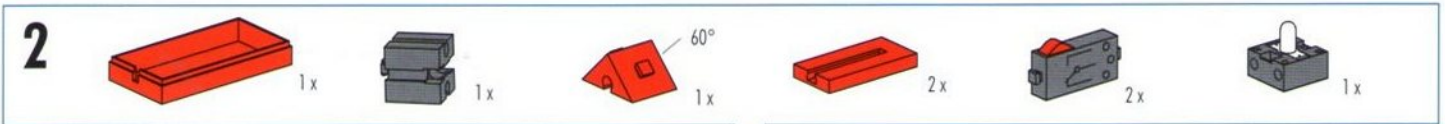
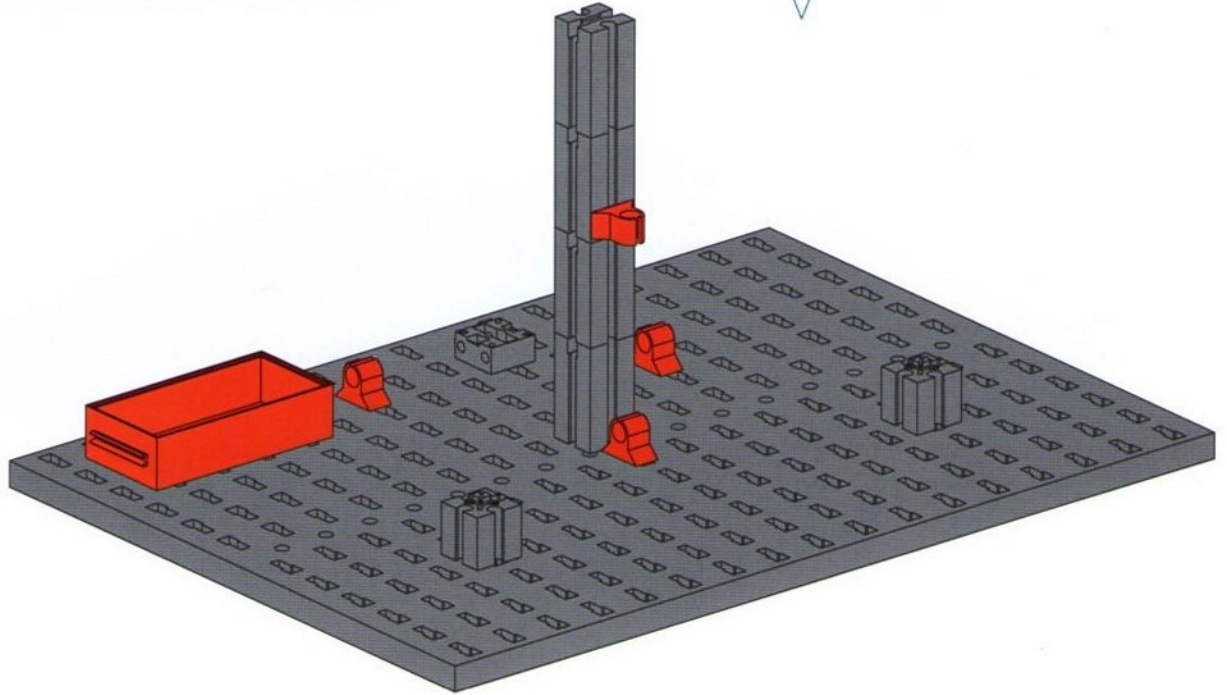
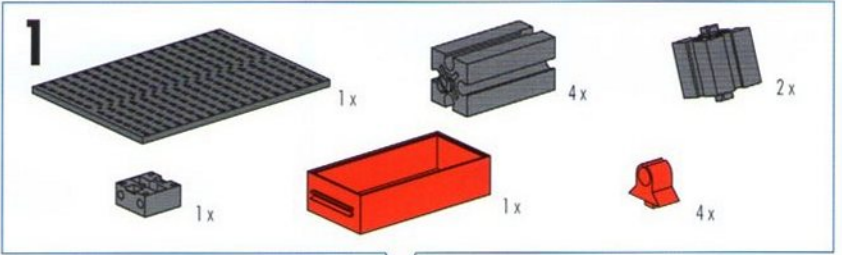
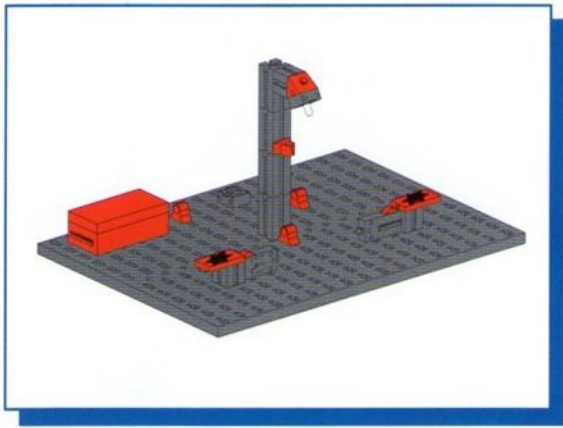

Kugellampe  
Bulb lamp  
Lampe sphérique  
Bolle lamp  
Lâmpada sferica  
Lâmpada esférica



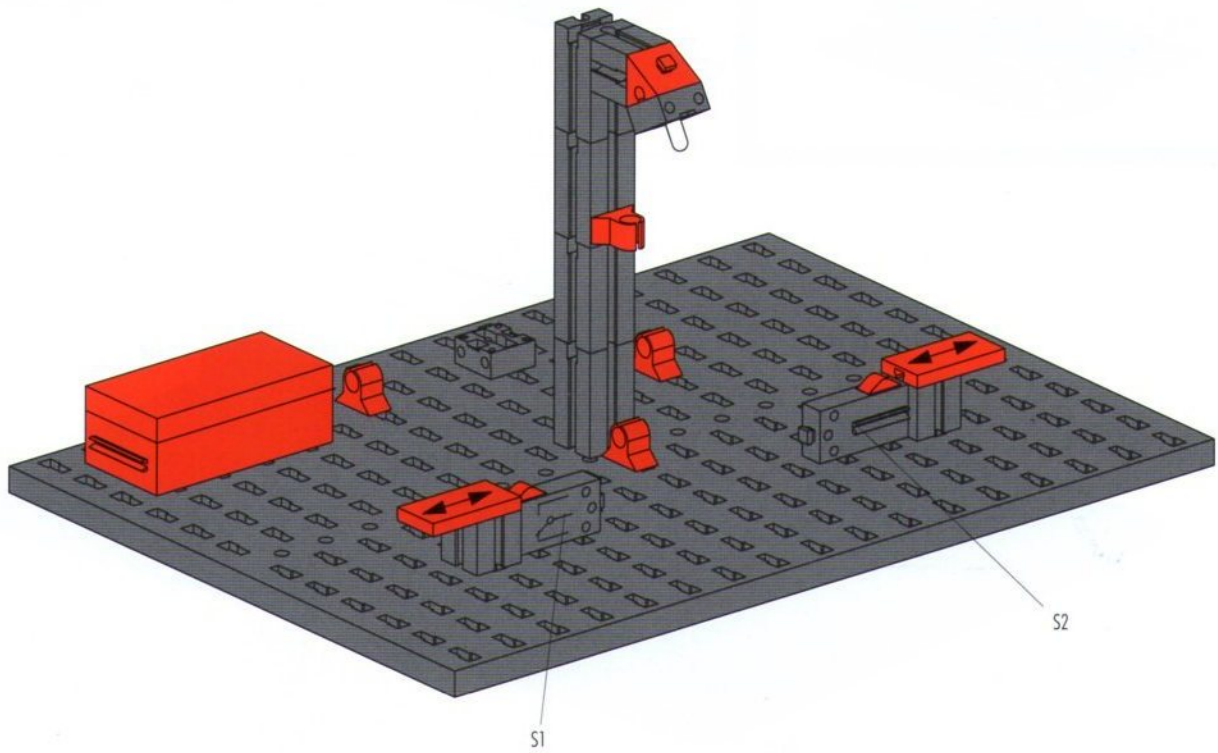

Schaltplan  
Circuit diagram  
Plan électrique

Schakelschema  
Diagrama de circuitos  
Plano elétrico de ligação

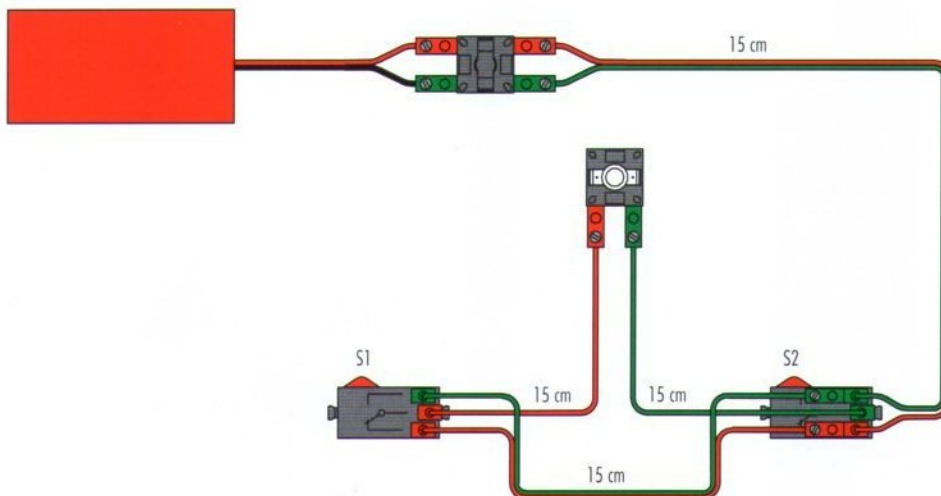

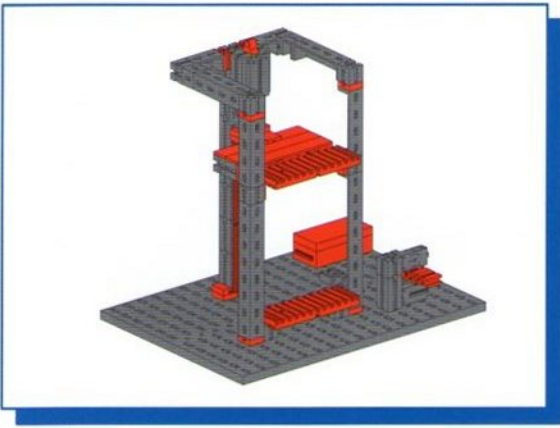

Aufzug  
Elevator  
Ascenseur

Lift  
Ascensor  
Elevador

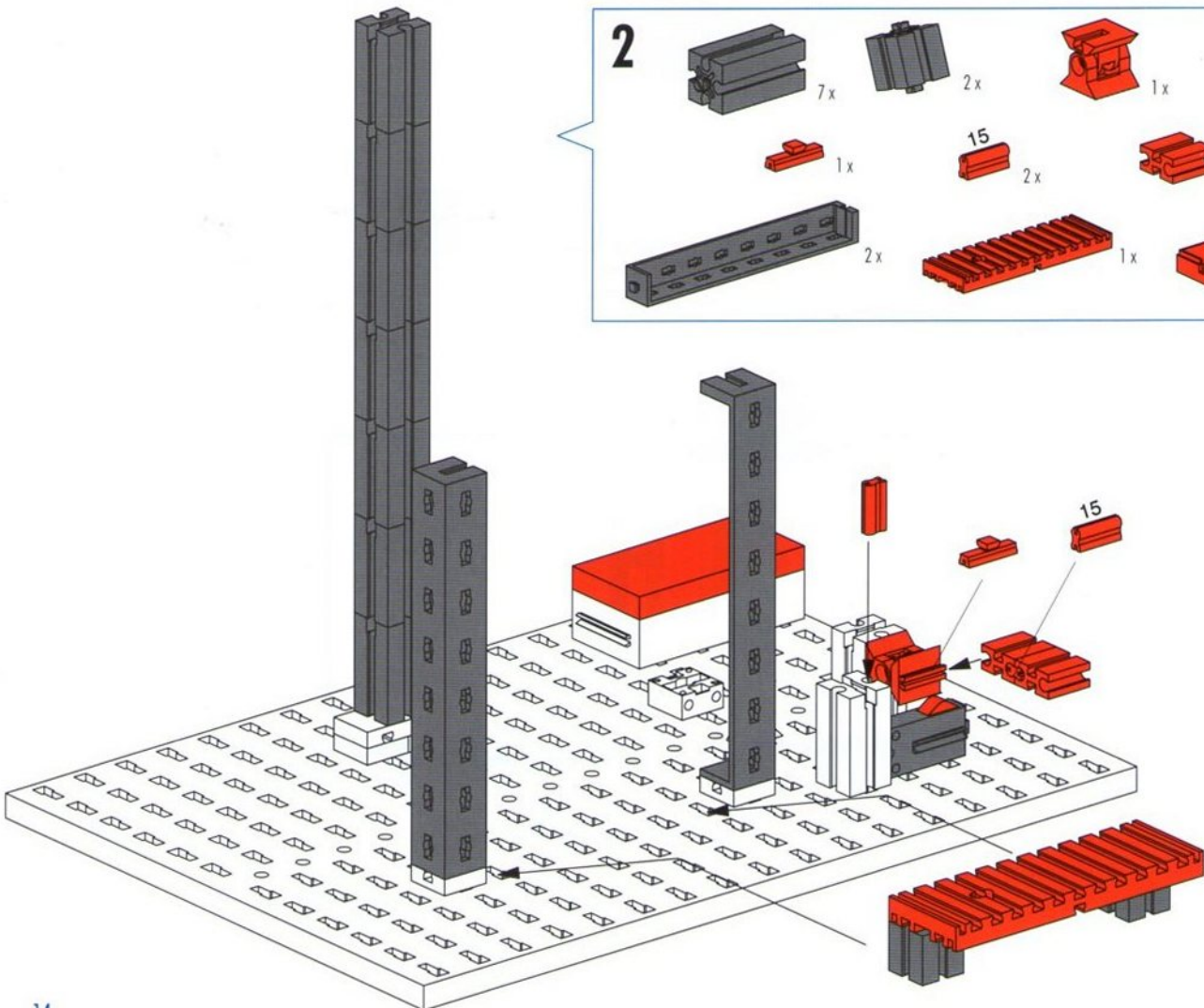
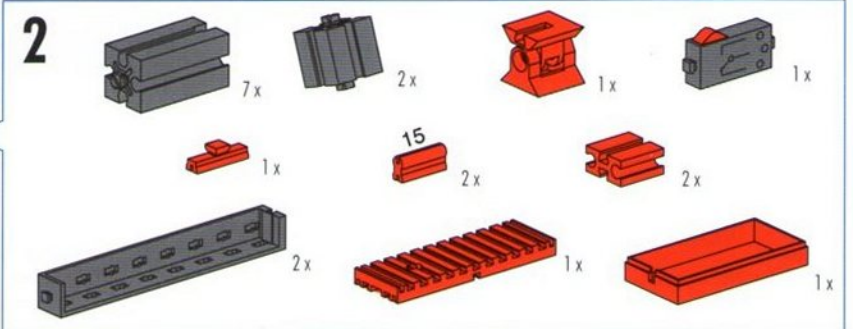
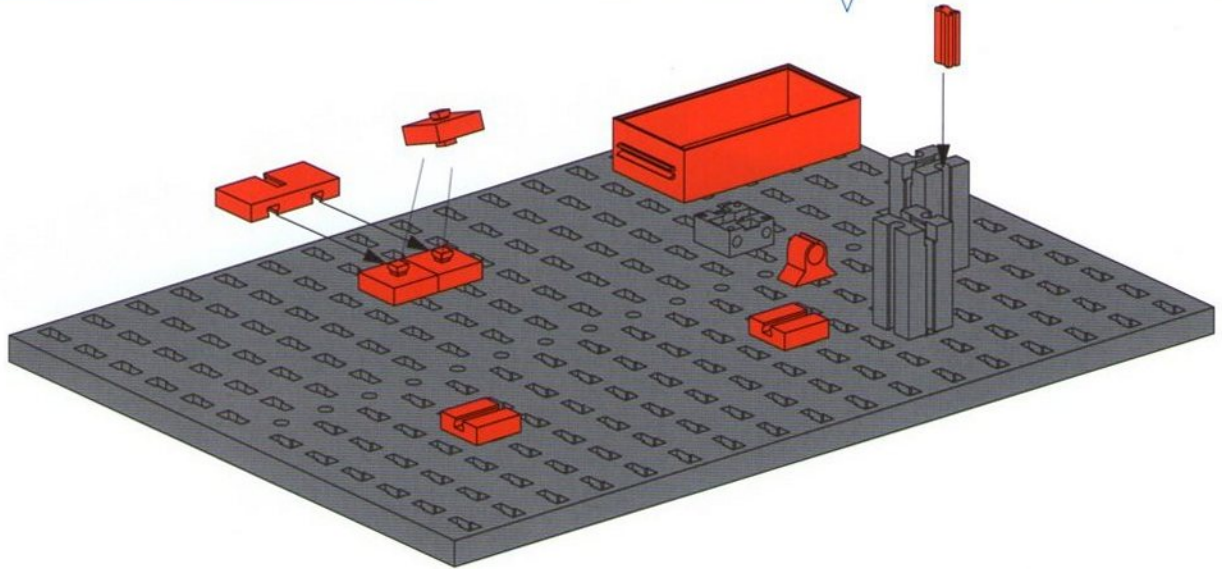
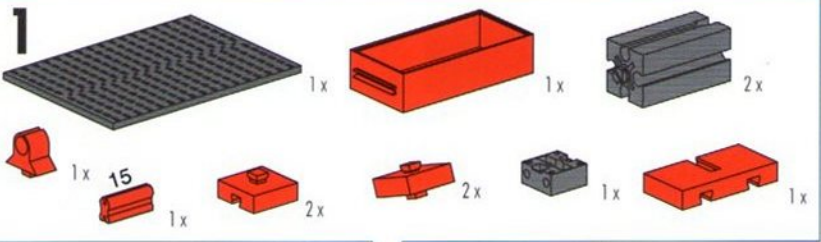



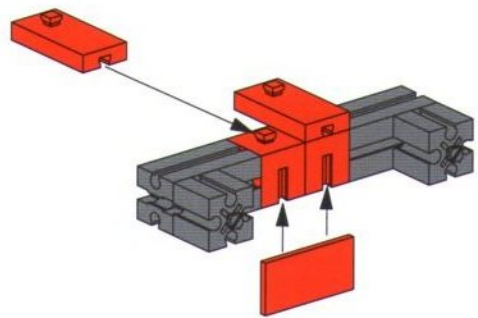
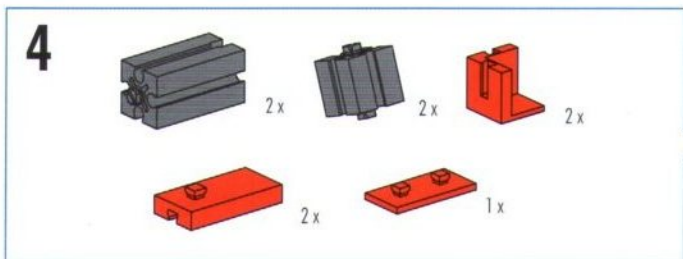
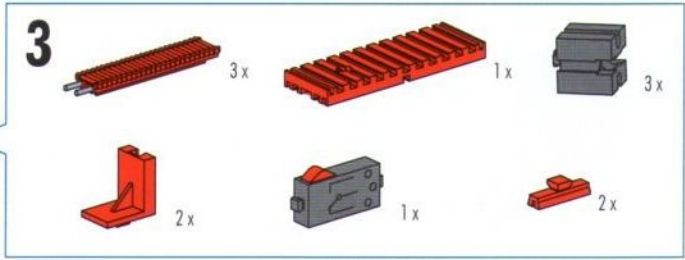
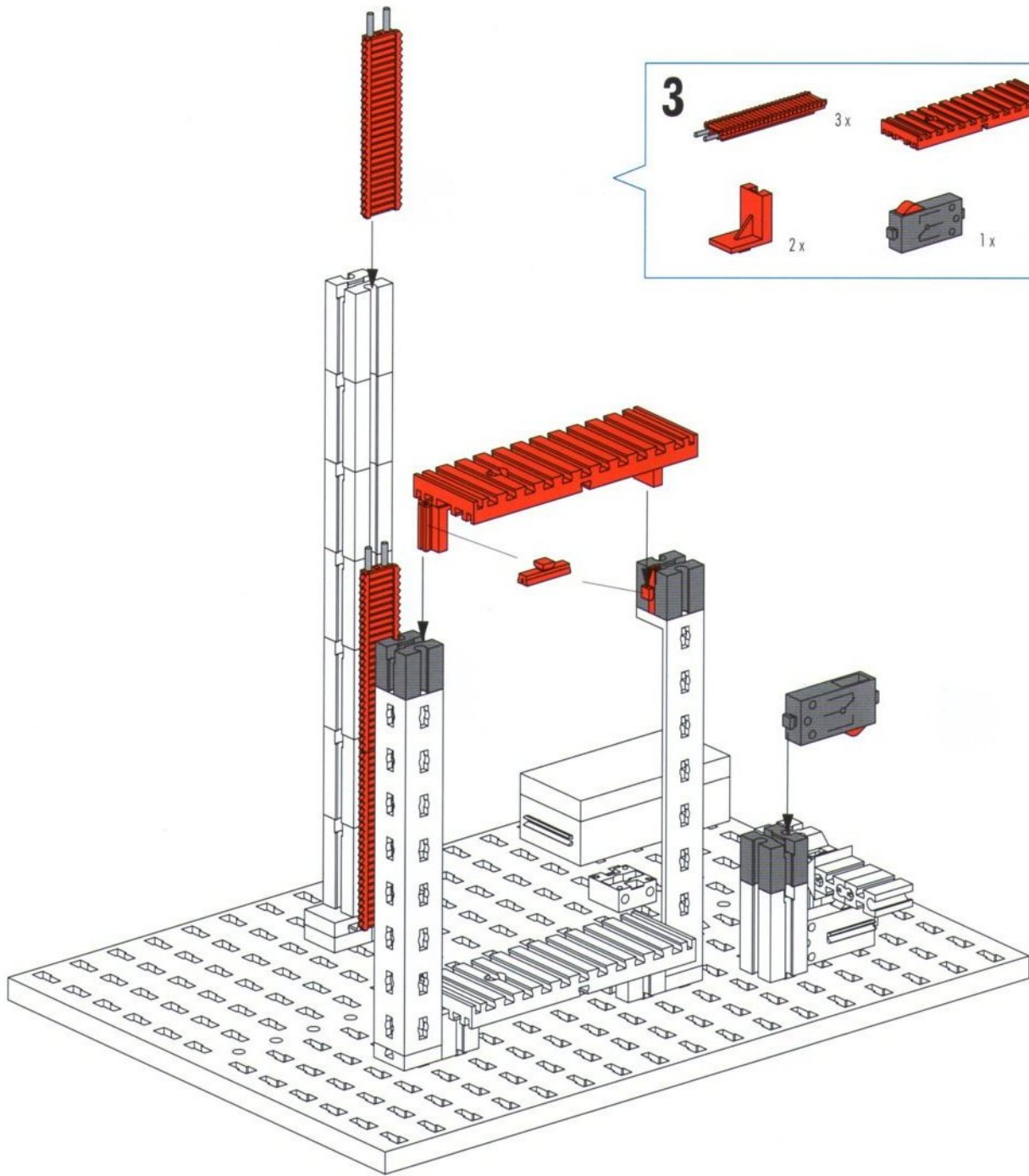

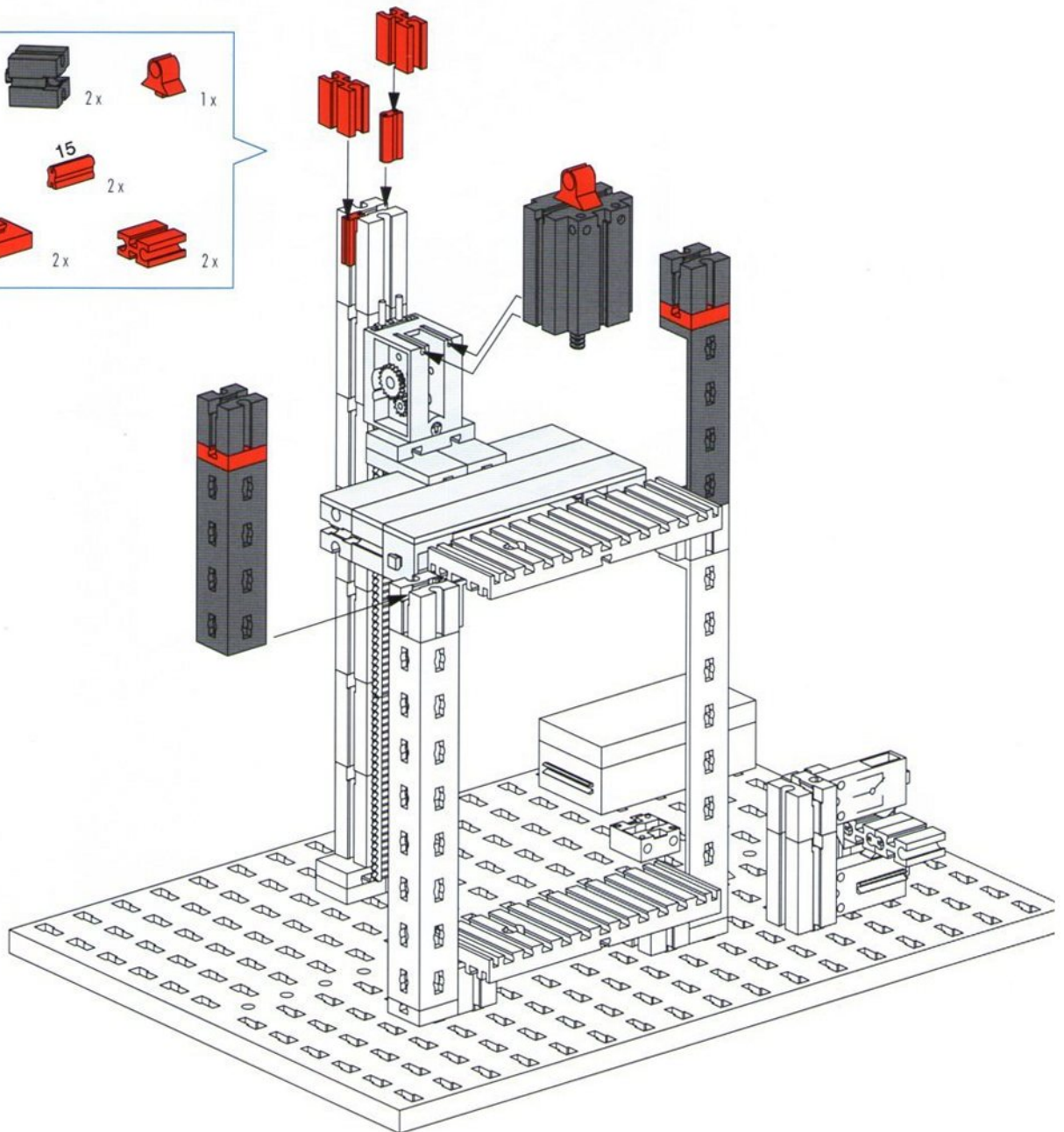
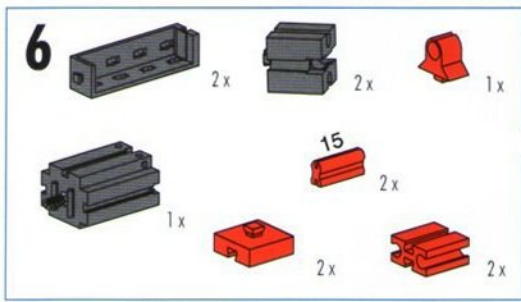
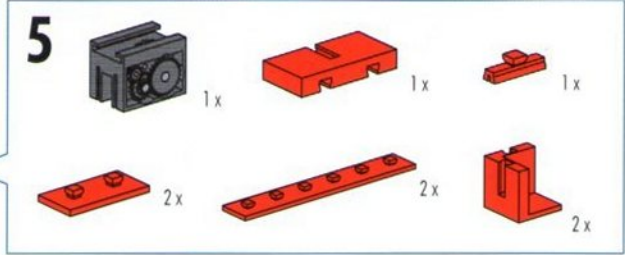
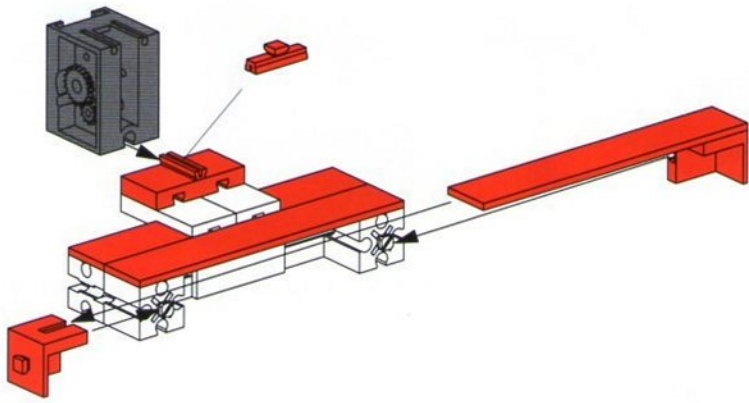



7

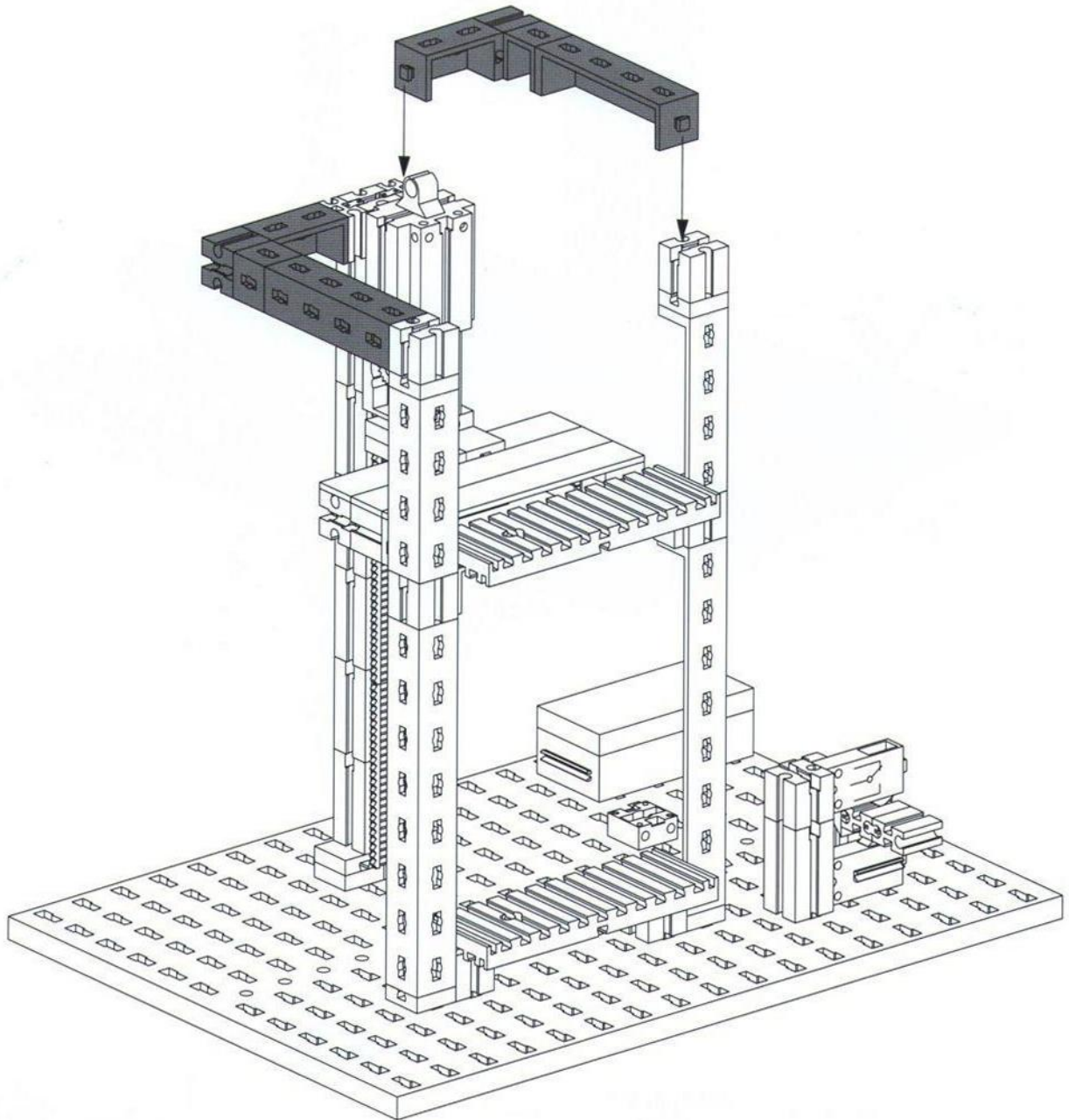

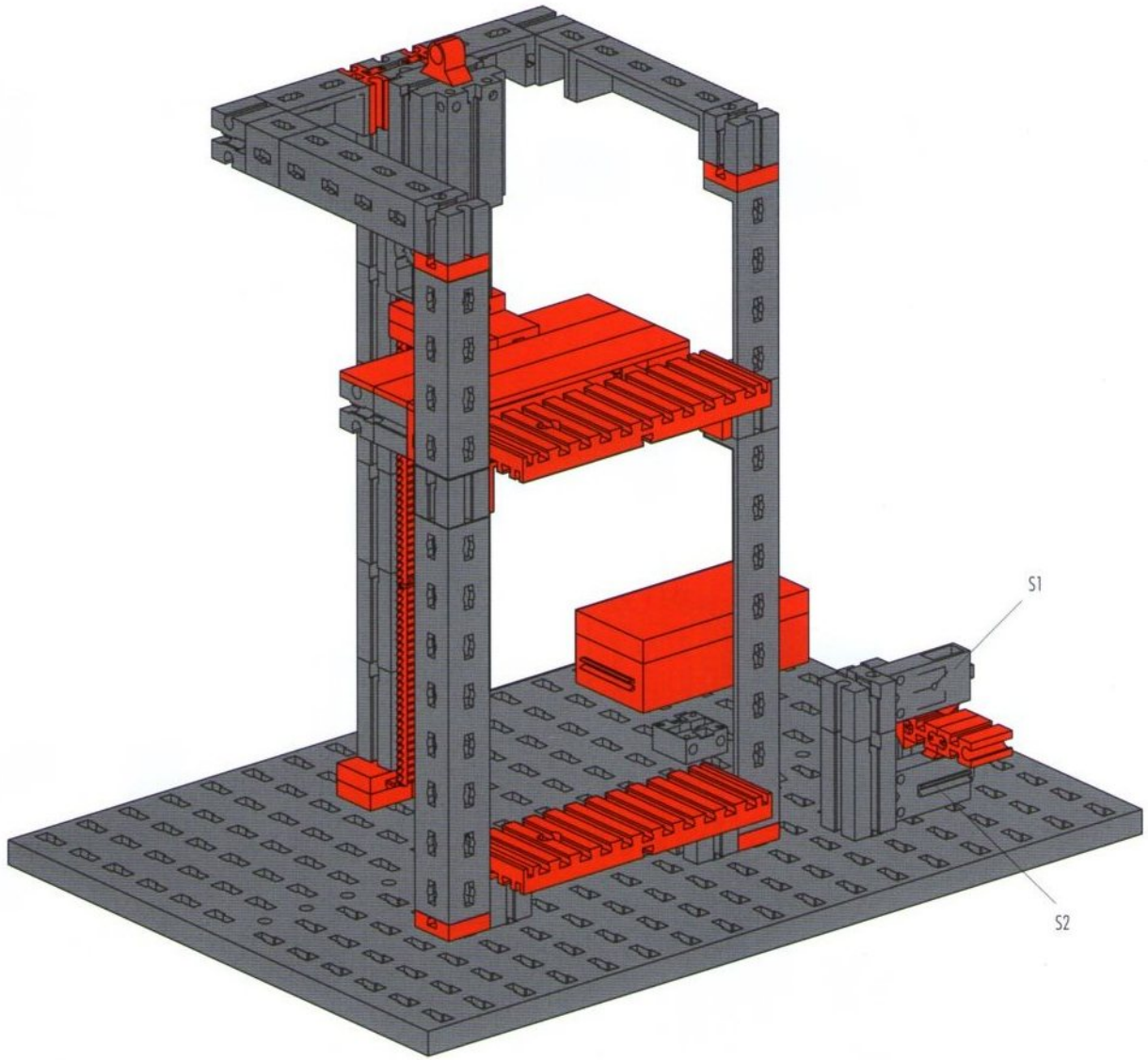

Schaltplan  
Circuit diagram  
Plan électrique

Schakelschema  
Diagrama de circuitos  
Plano elétrico de ligação

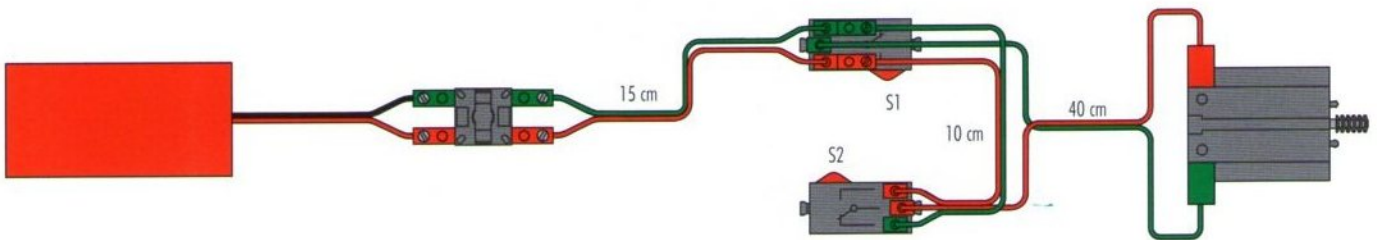



**Einfaches Blinklicht**  
**Simple flash light**  
**Feu clignotant simple**

**Eenvoudig knipperlicht**  
**Luz intermitente sencilla**  
**Lâmpada intermitente**

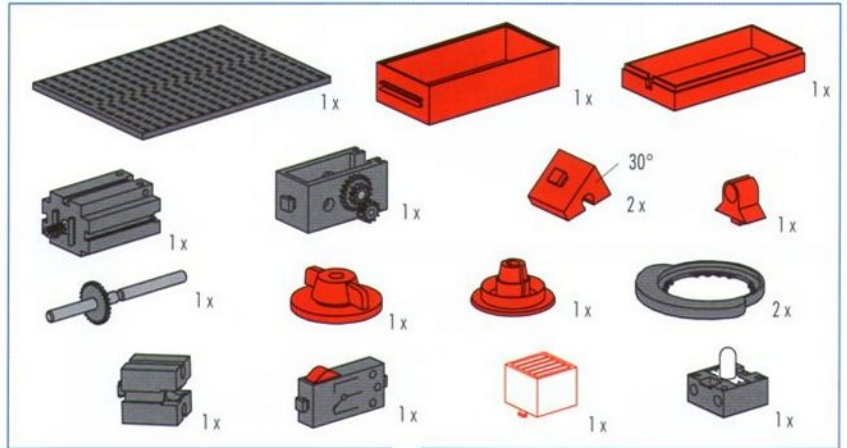
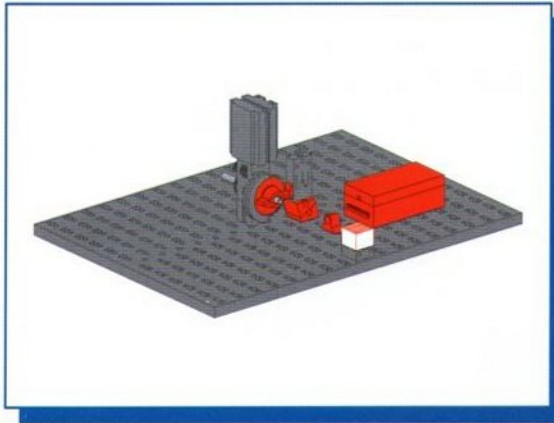

Kugellampe  
 Bulb lamp  
 Lampe sphérique  
 Bolle lamp  
 Lâmpada sferica  
 Lâmpada esférica

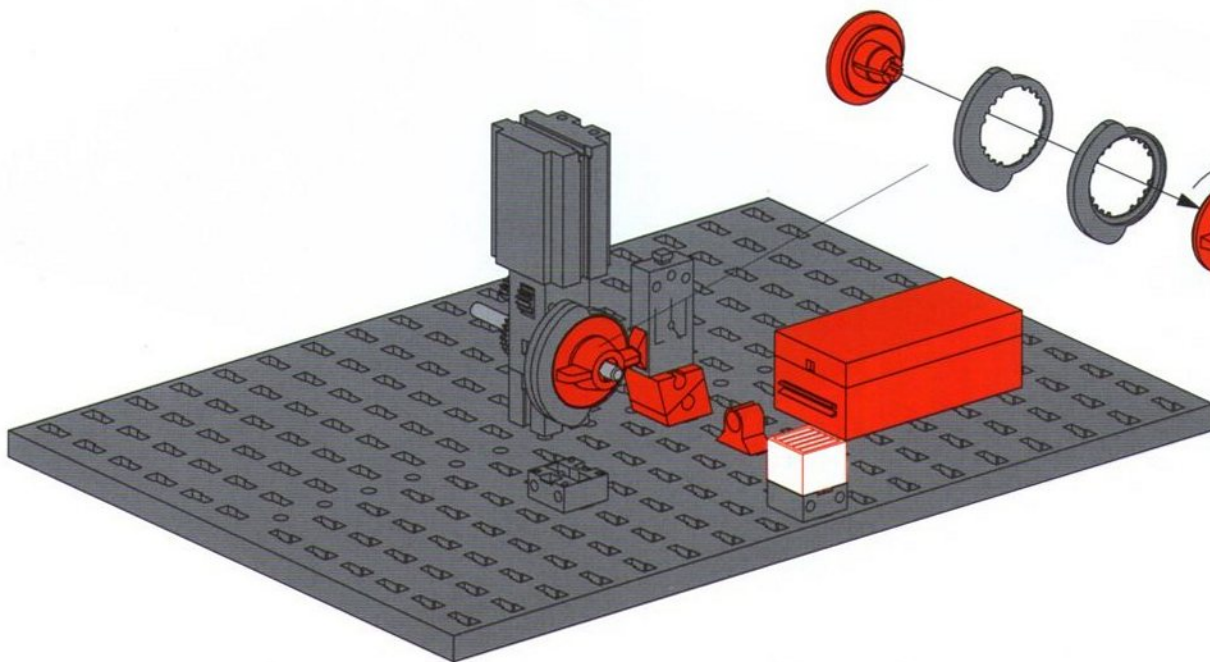

Schaltplan  
 Circuit diagram  
 Plan électrique



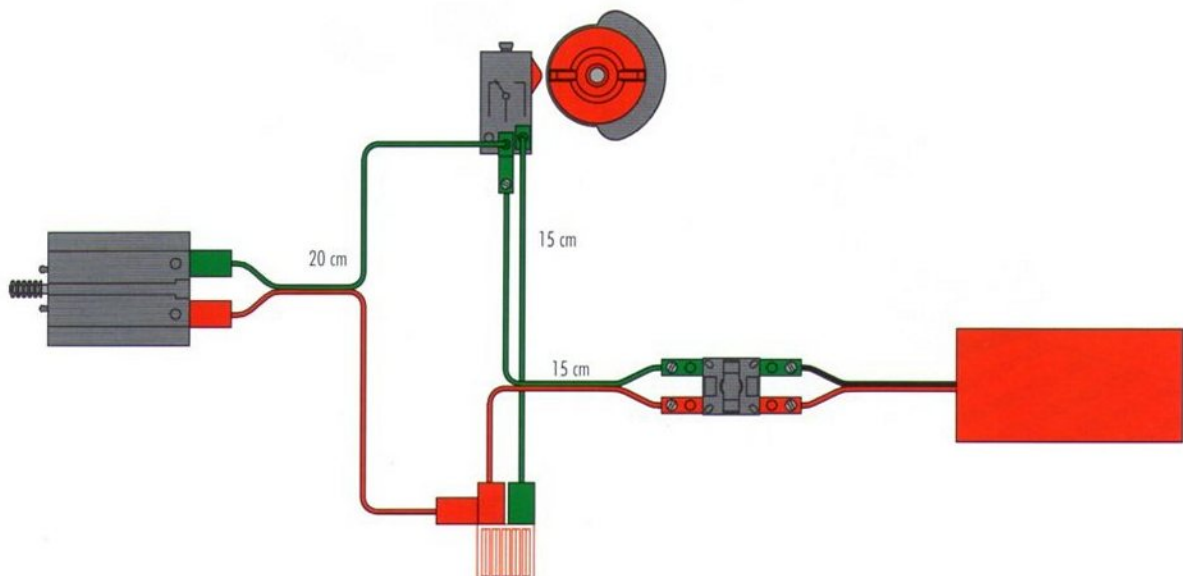

Schakelschema  
 Diagrama de circuitos  
 Plano elétrico de ligação



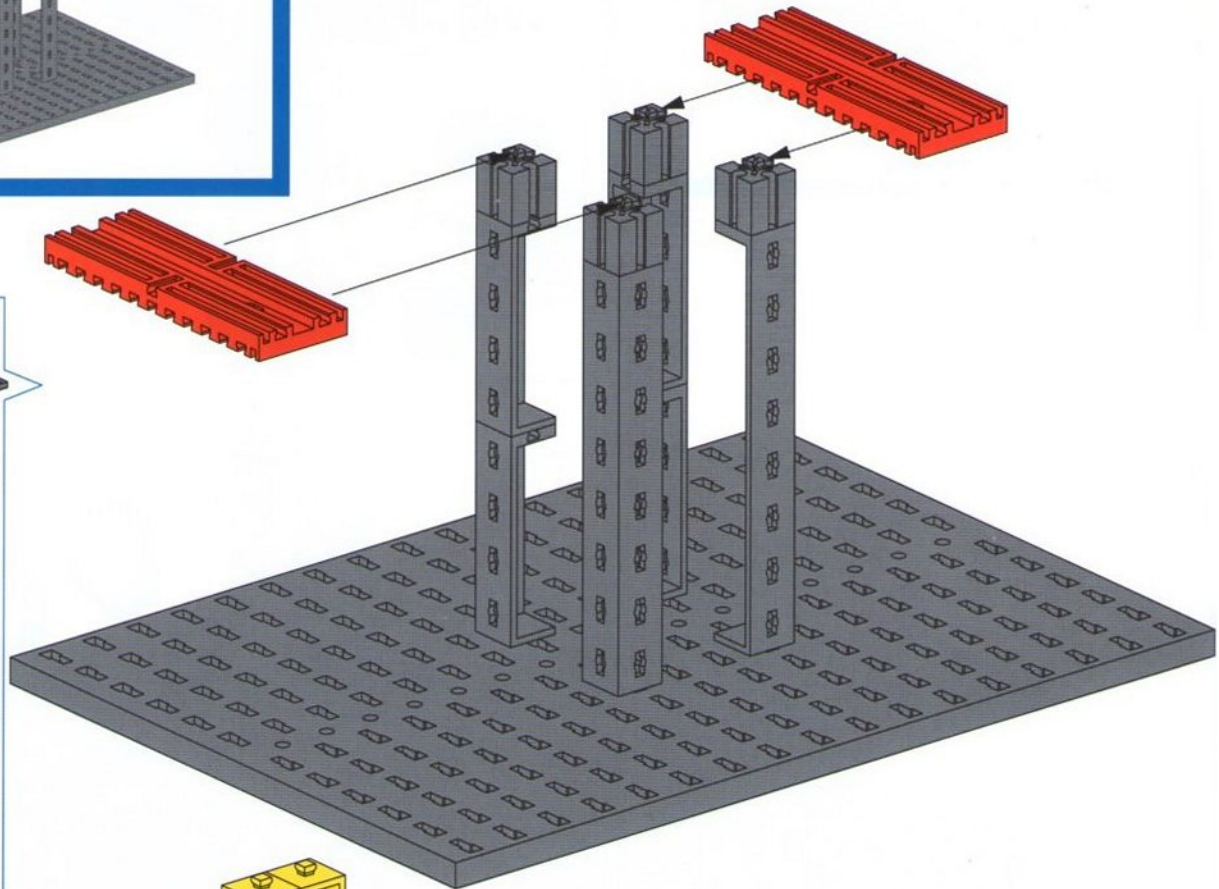



**Turm mit Warnblinklicht**  
**Tower with blinking warning light**  
**Tour avec feux de détresse**

**Toren met knipperlicht**  
**Column with luz de aviso de emergencia**  
**Torre com luz de aviso**

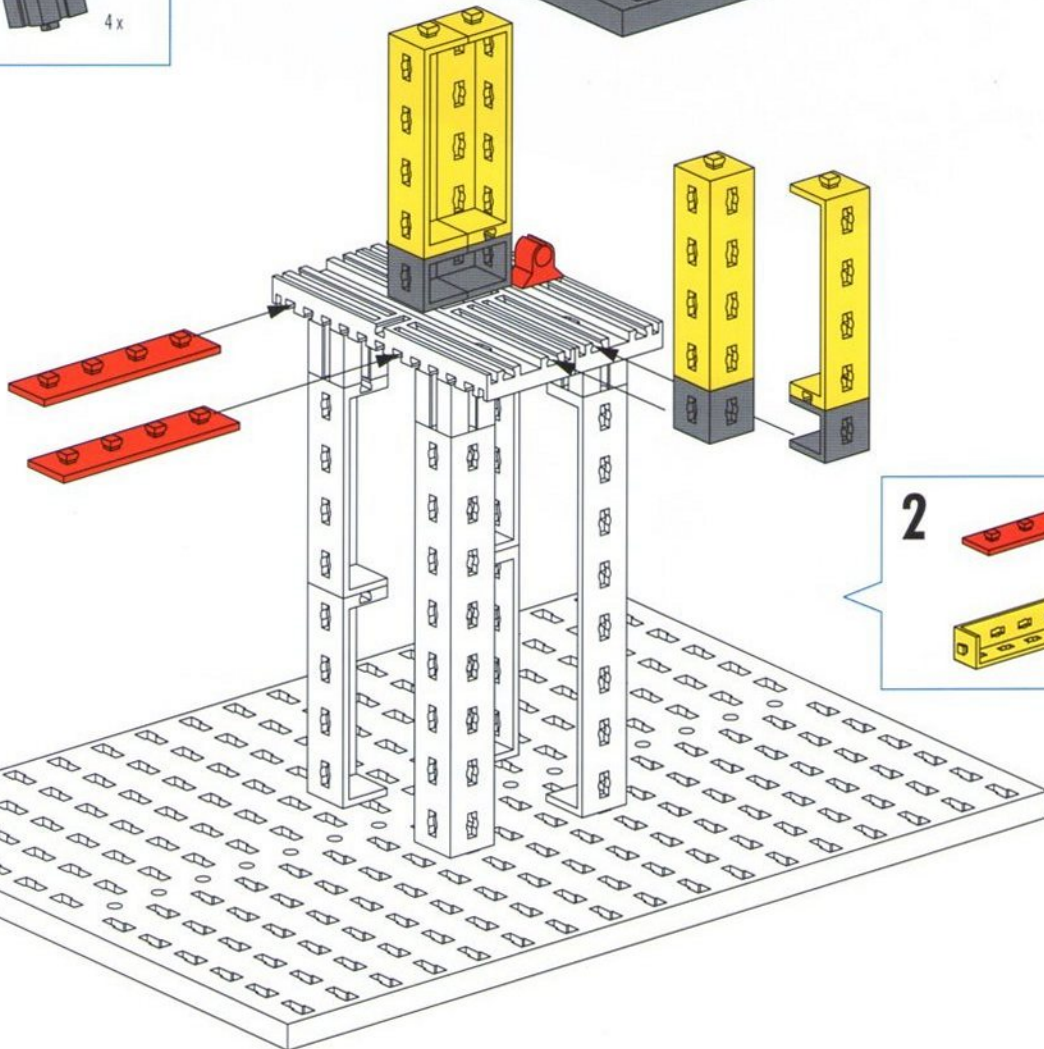

- 1**
-  1 x
  -  2 x
  -  4 x
  -  2 x
  -  4 x



- 2**
-  2 x
  -  1 x
  -  4 x
  -  4 x



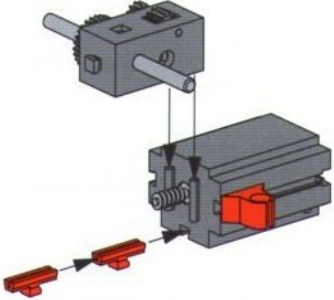
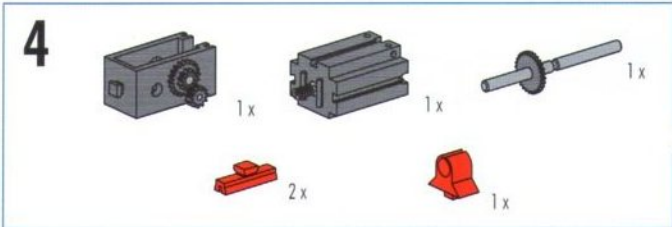
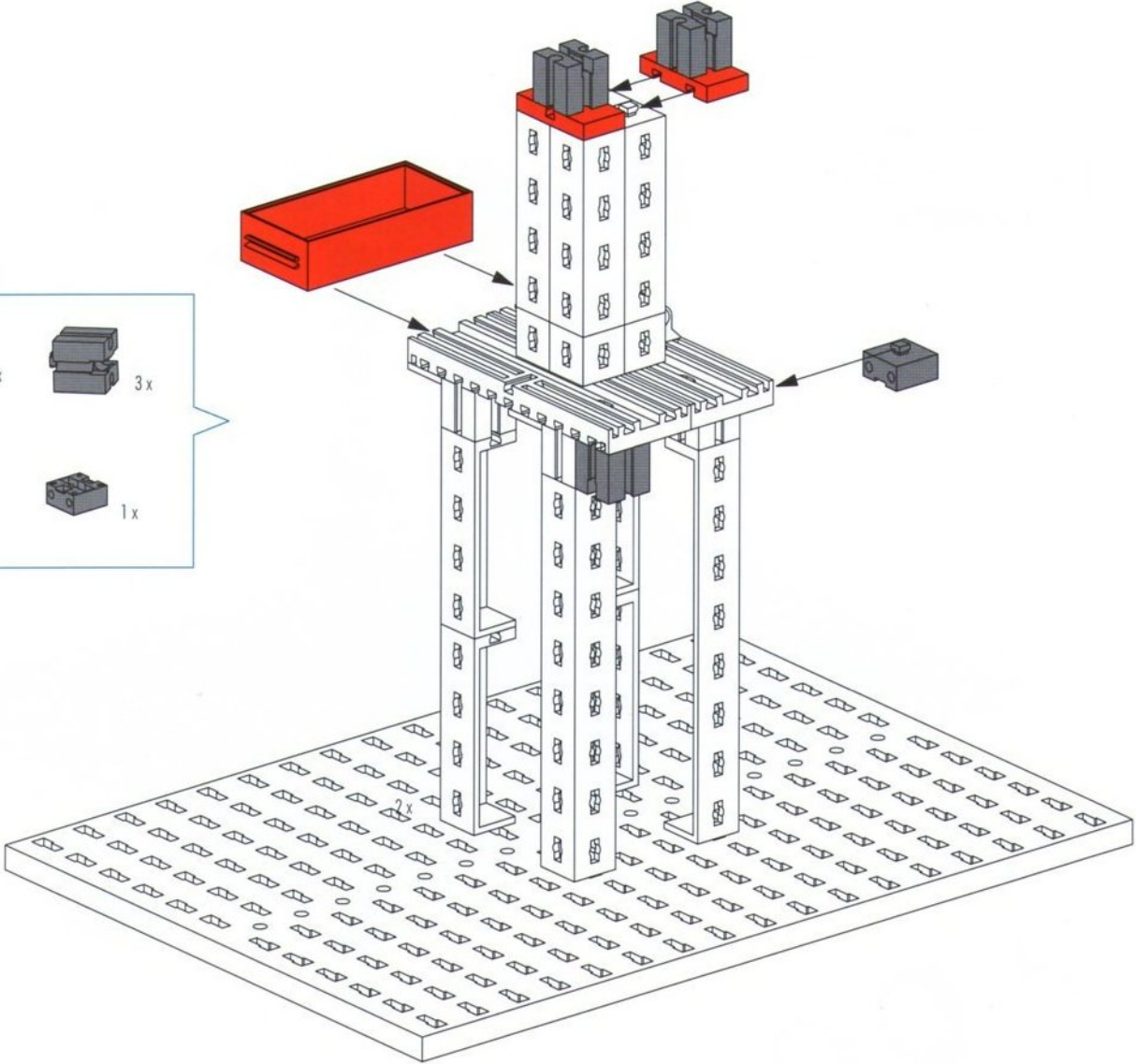
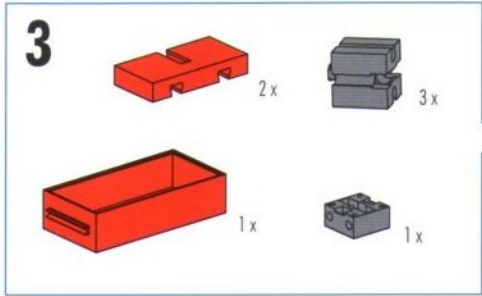

5



1x



1x



1x



1x



1x



2x



1x



1x



1x



2x

Kugellampe  
 Bulb lamp  
 Lampe sphérique  
 Bolle lamp  
 Lâmpada sferica  
 Lâmpada esférica

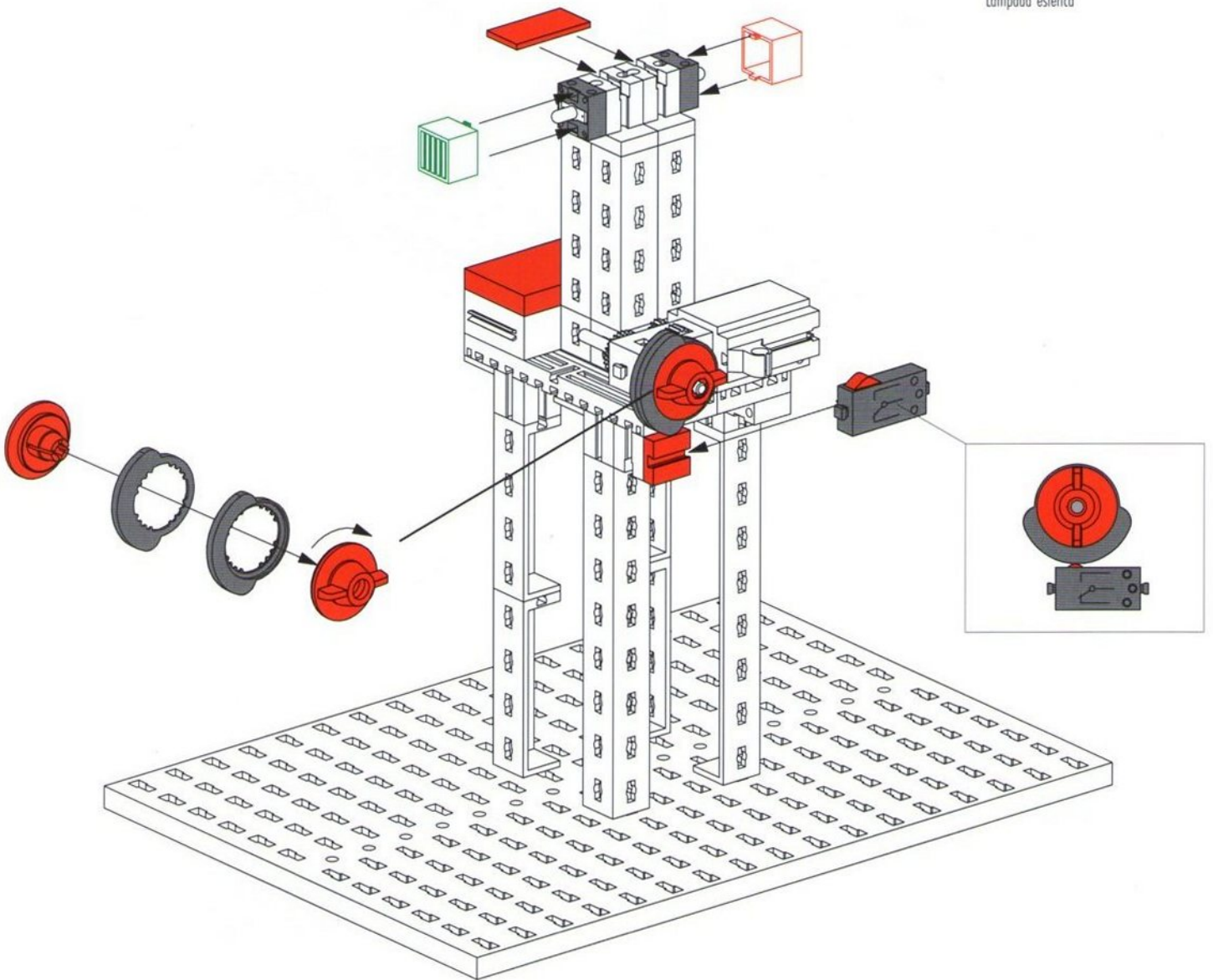



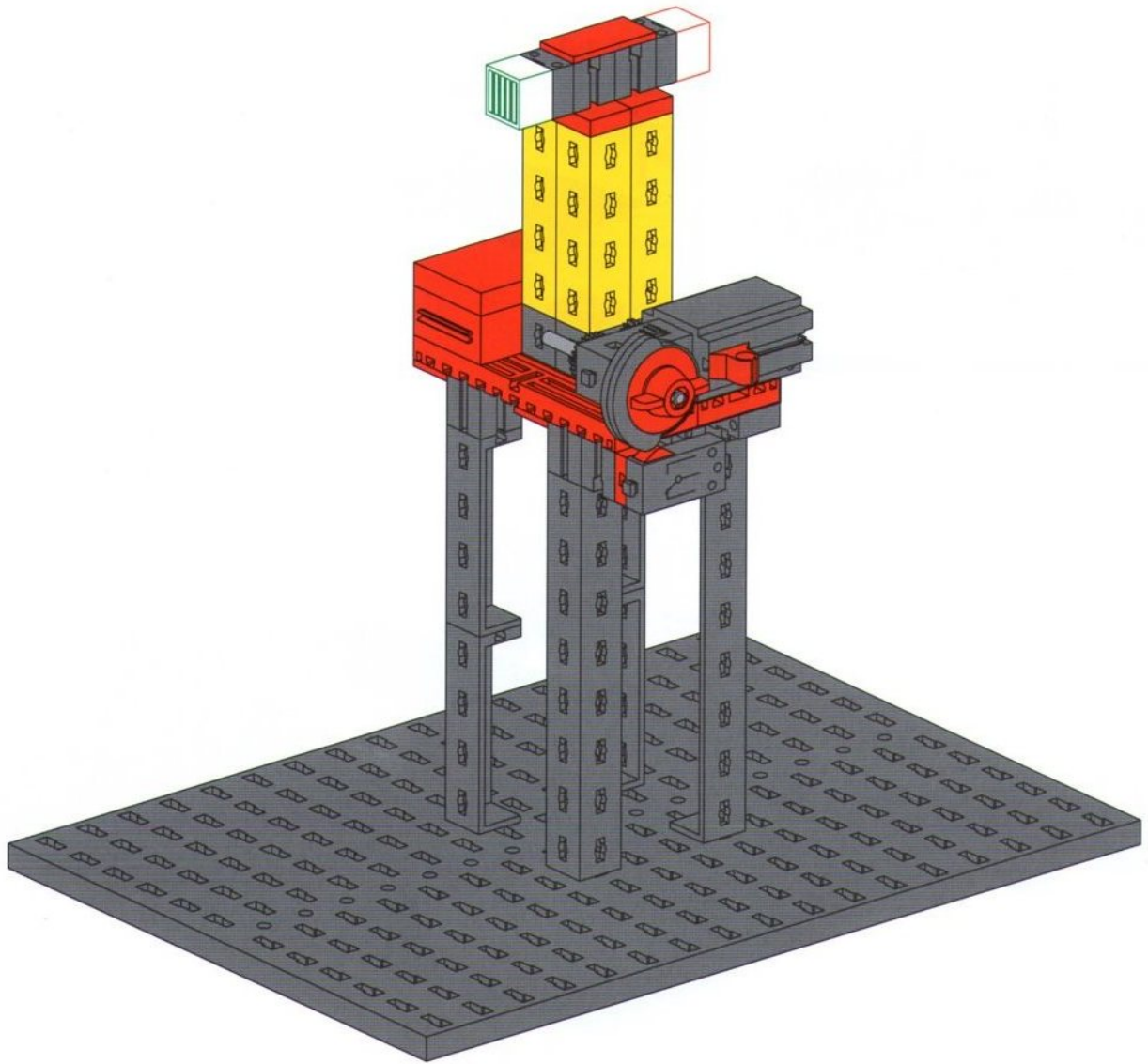

Schaltplan  
Circuit diagram  
Plan électrique

Schakelschema  
Diagrama de circuitos  
Plano elétrico de ligação

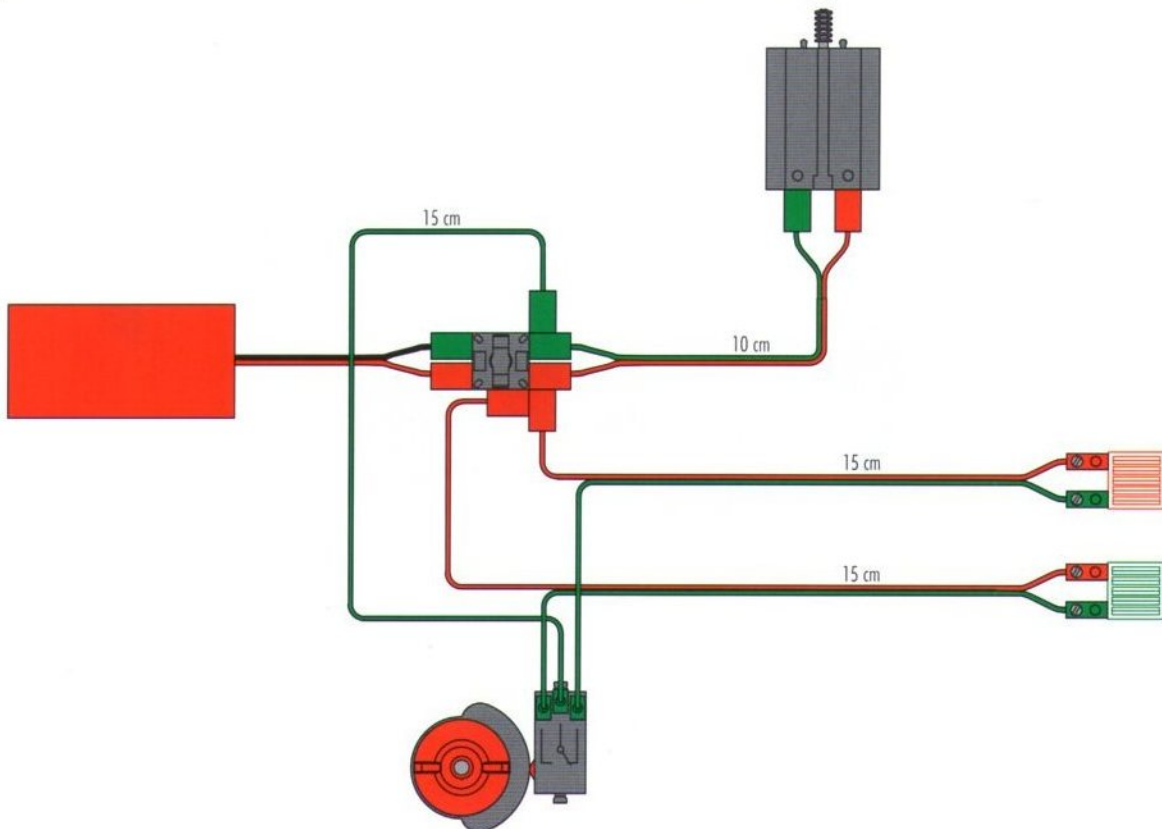

Ampelsteuerung  
Traffic light control  
Commande des feux de signalisation

Regeling van een verkeerslicht  
Mando del semáforo  
Comando de semáforo

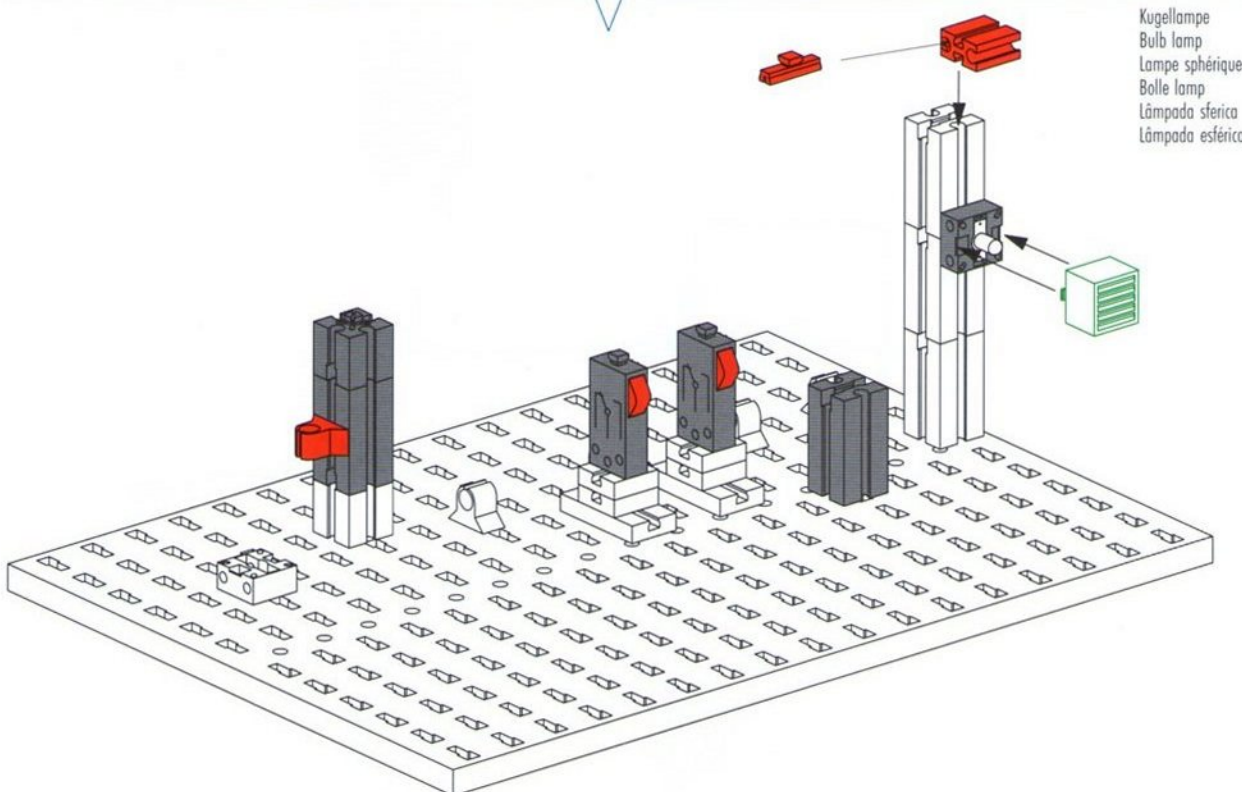
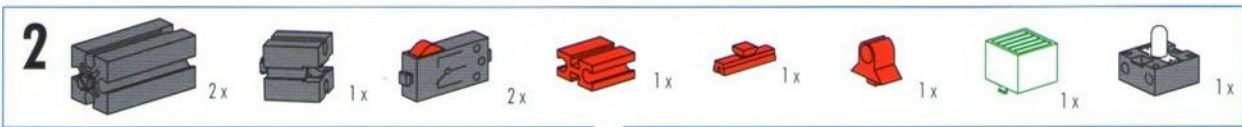
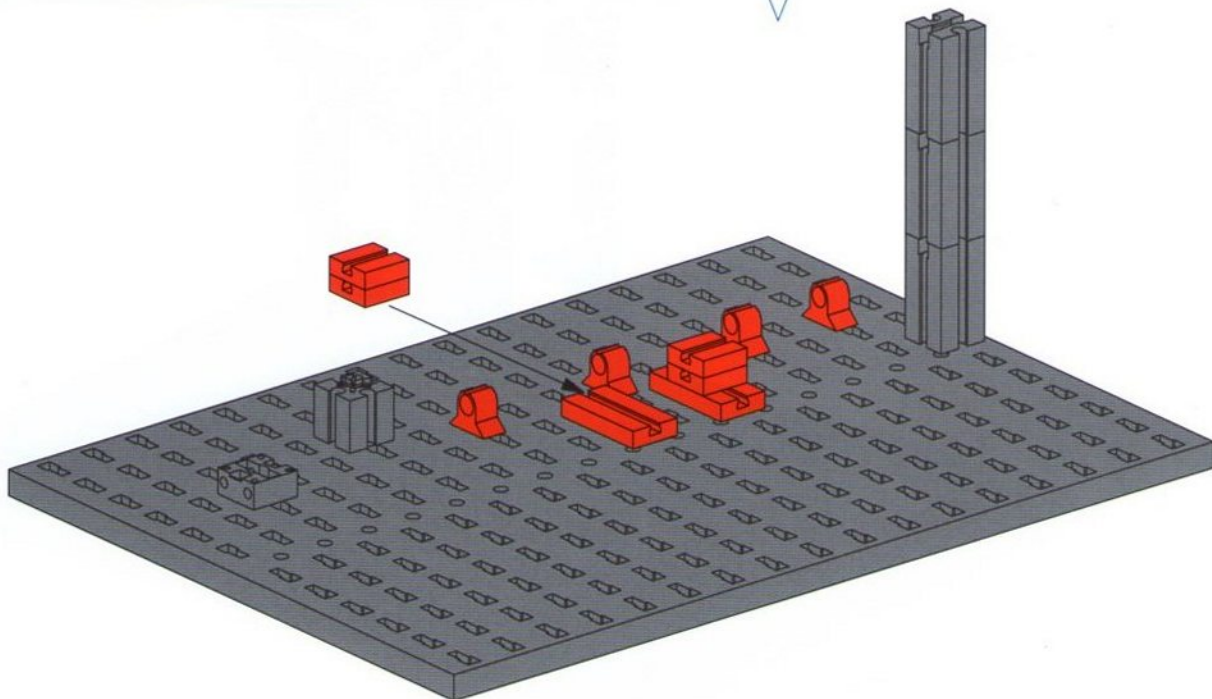
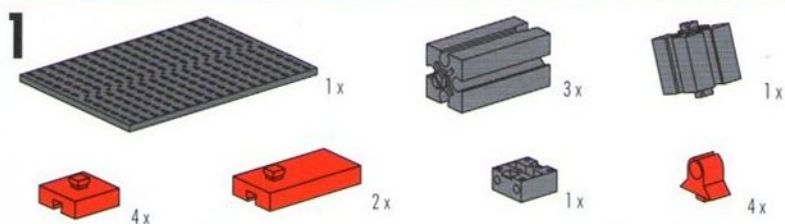
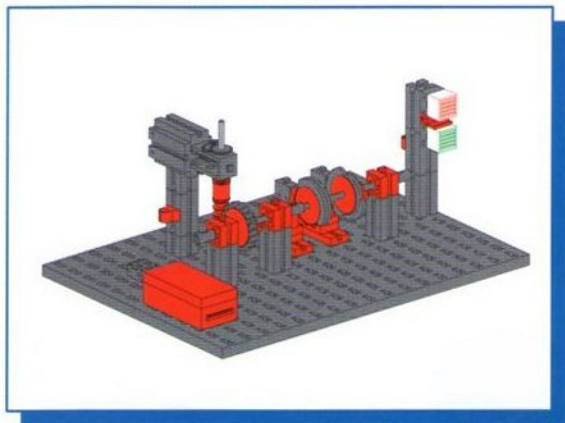



3

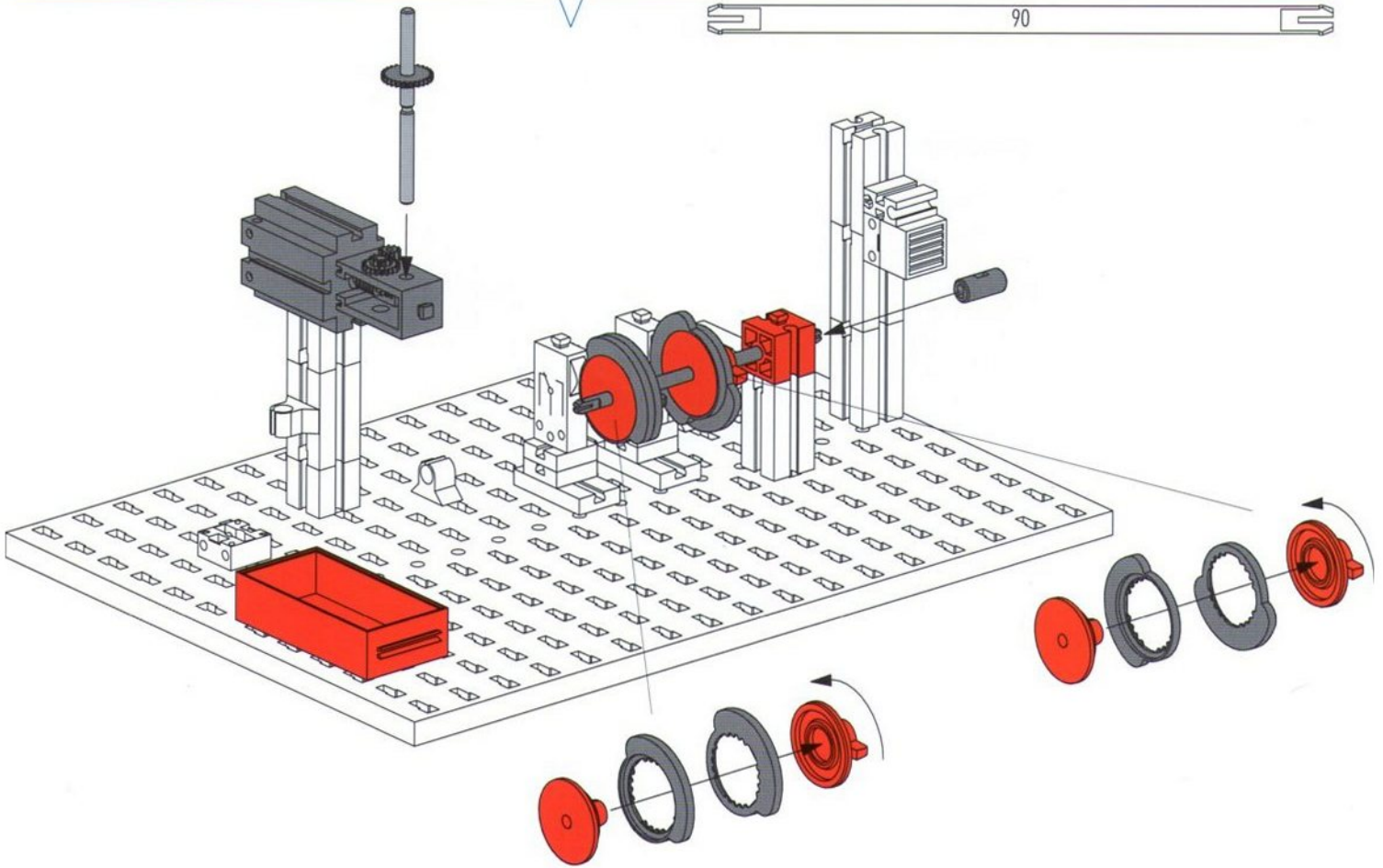
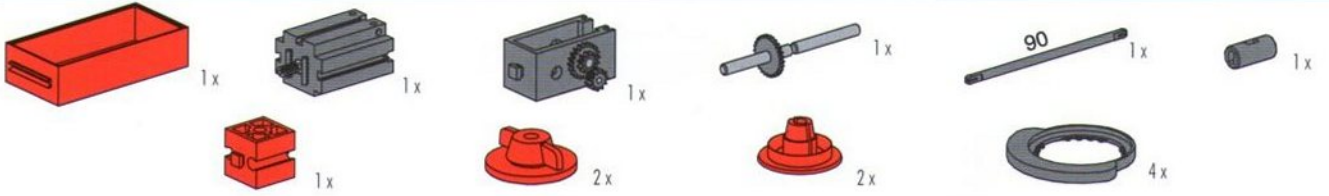

4

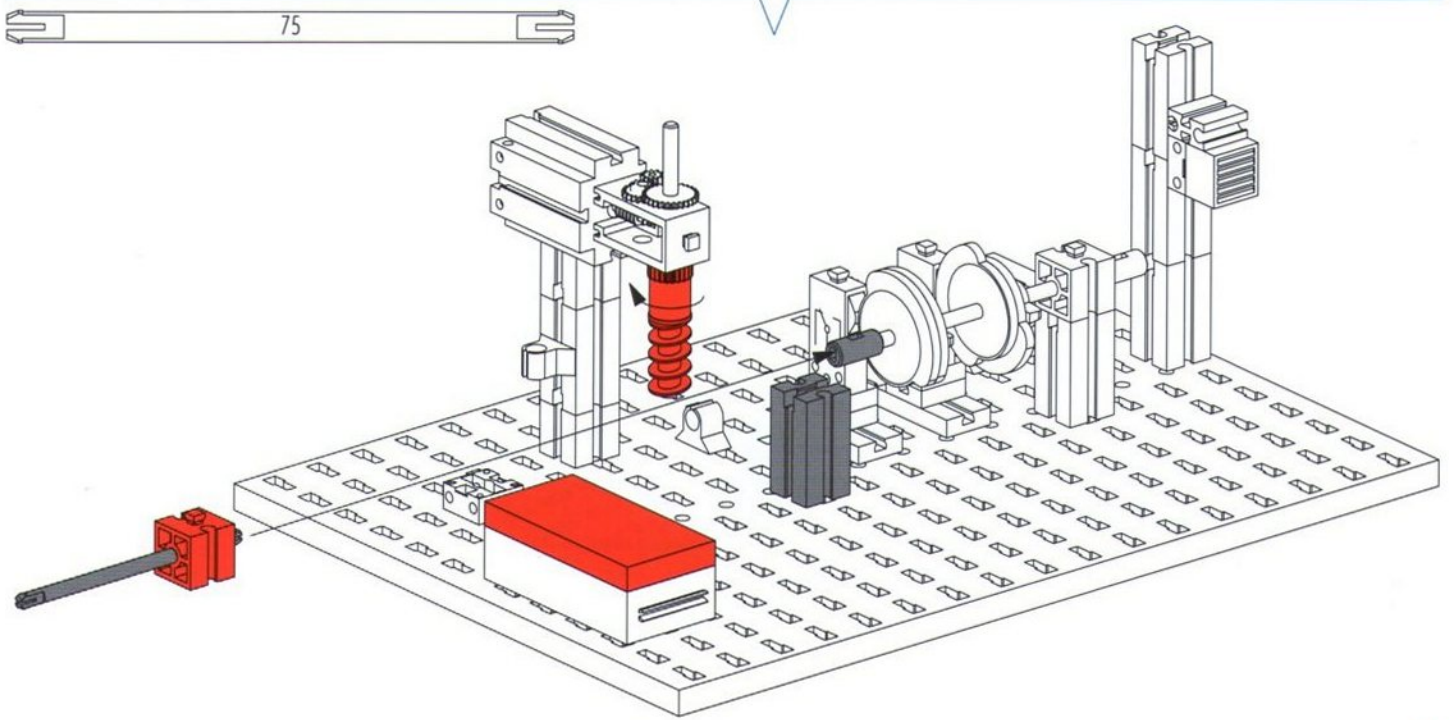



Kugellampe  
 Bulb lamp  
 Lampe sphérique  
 Bolle lamp  
 Lâmpada sferica  
 Lâmpada esférica

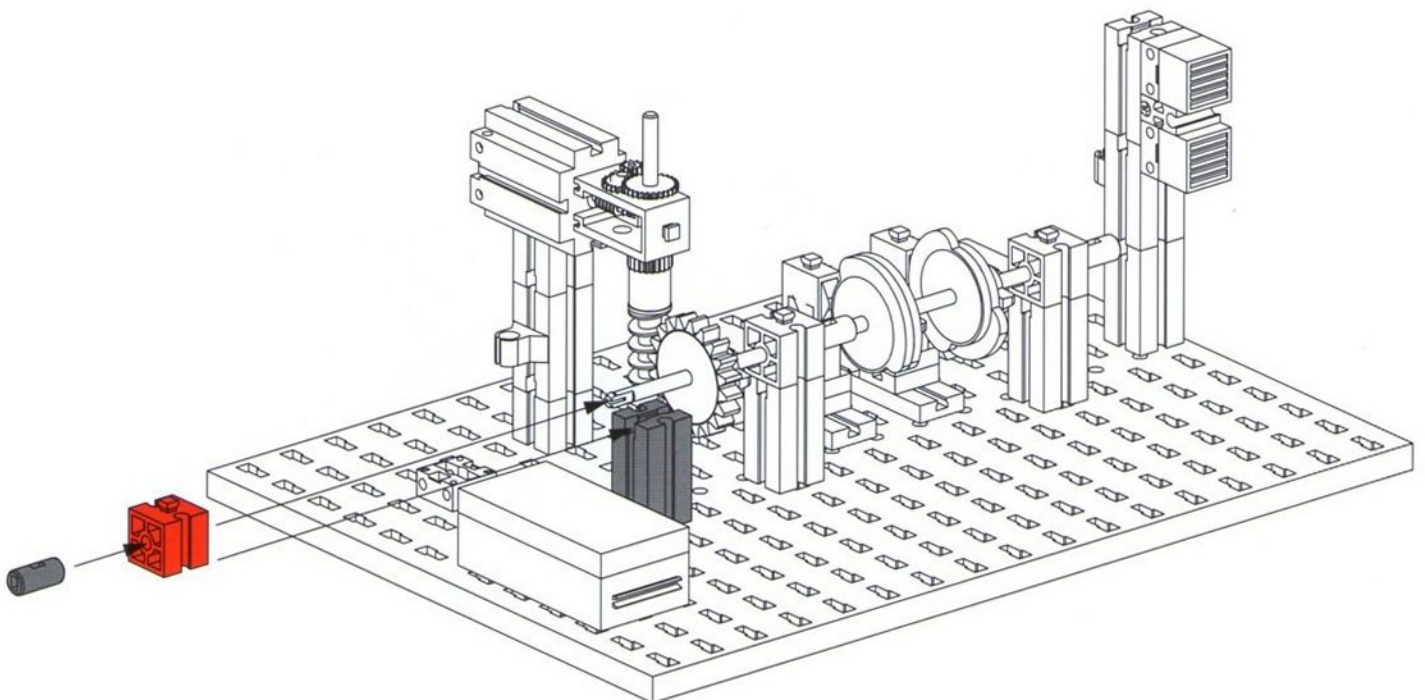
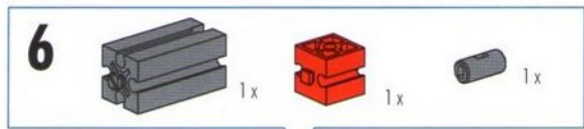
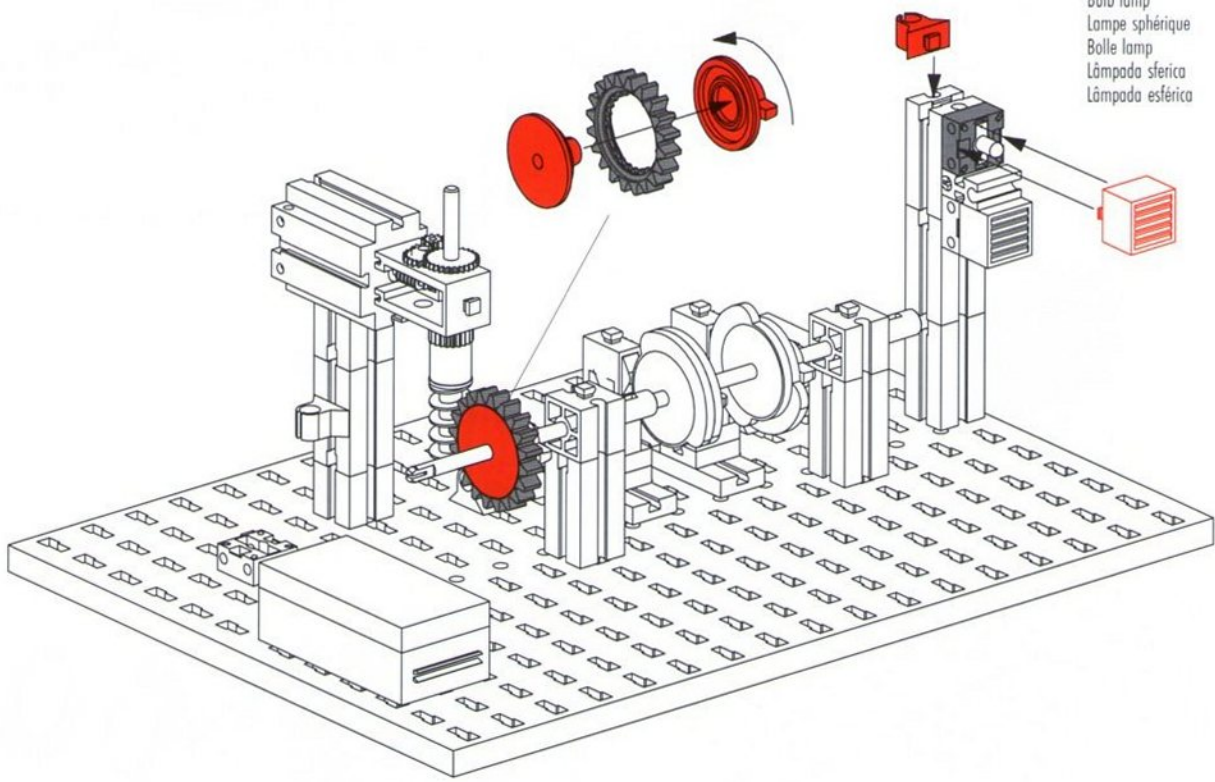



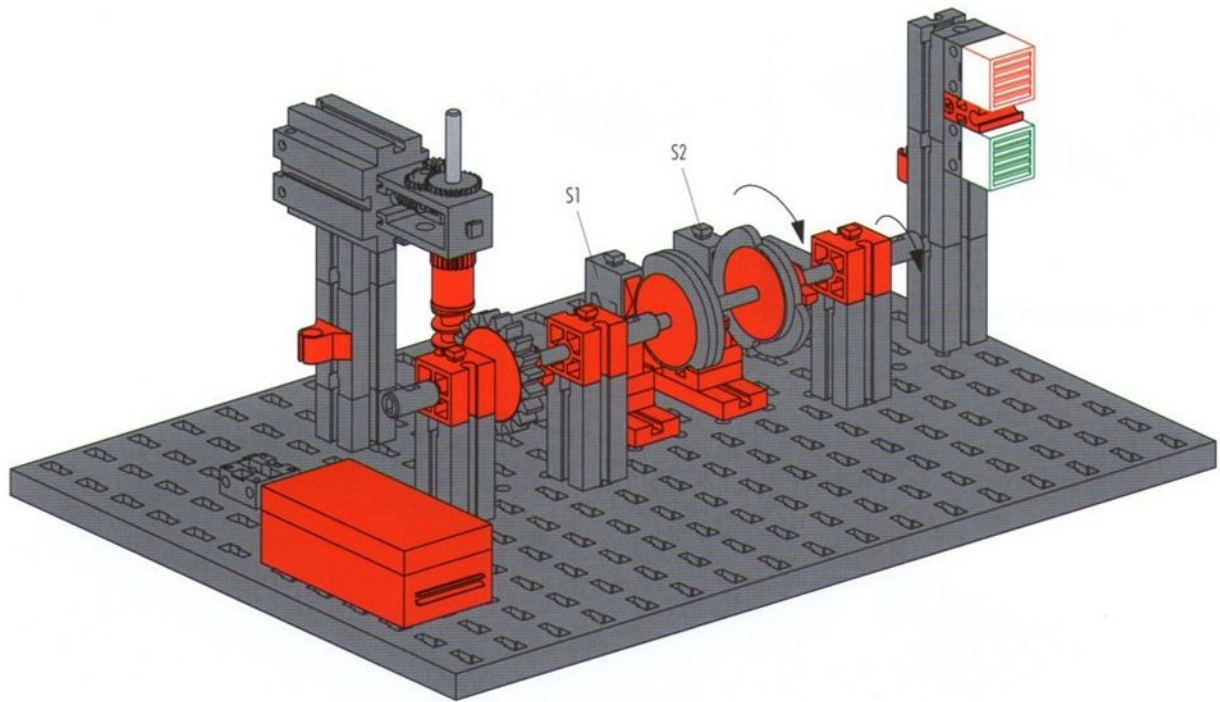

Schaltplan  
Circuit diagram  
Plan électrique

Schakelschema  
Diagrama de circuitos  
Plano elétrico de ligação

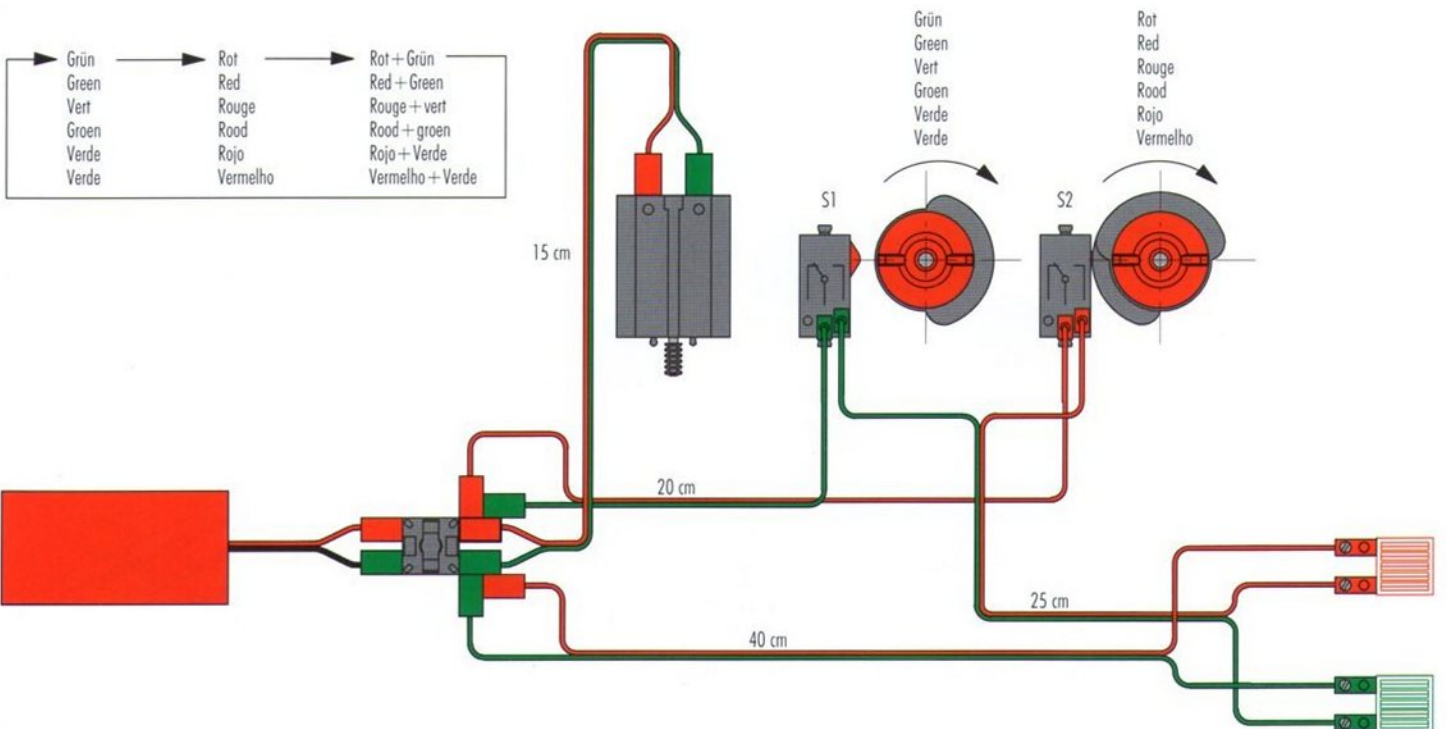





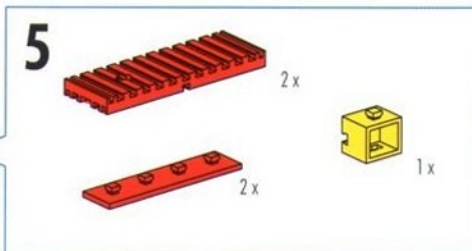
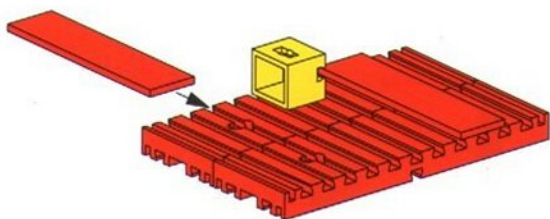
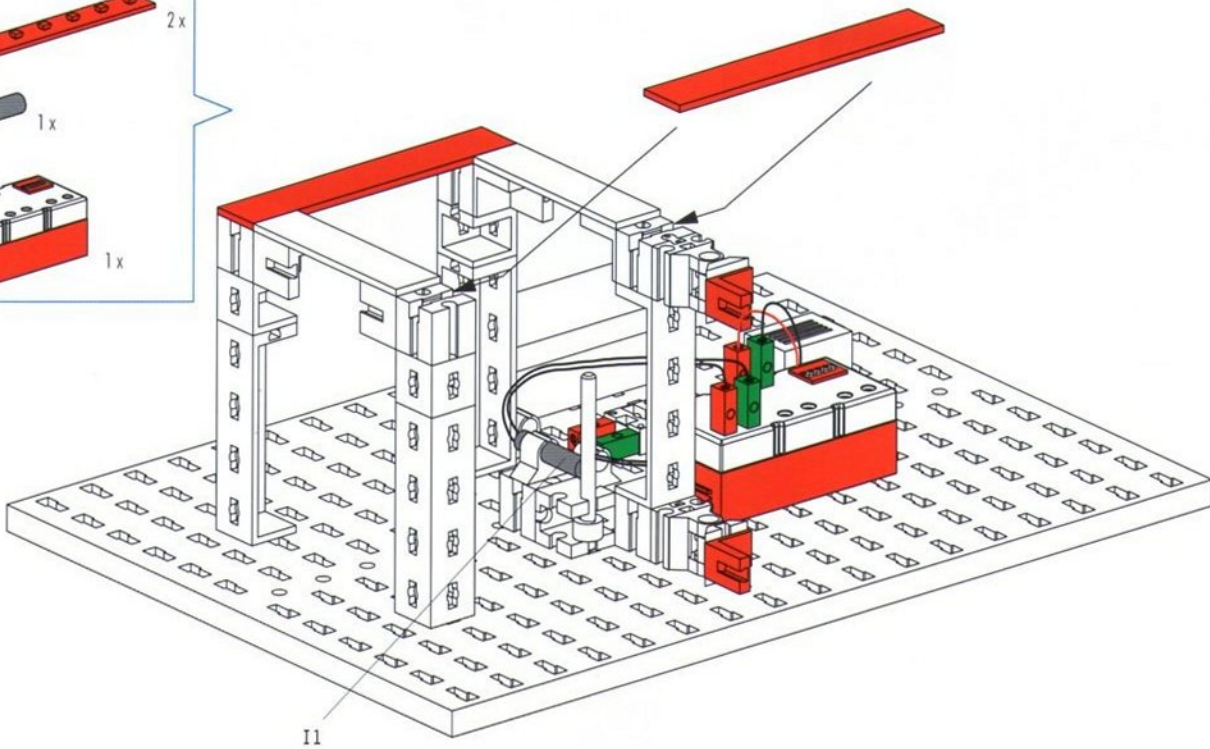
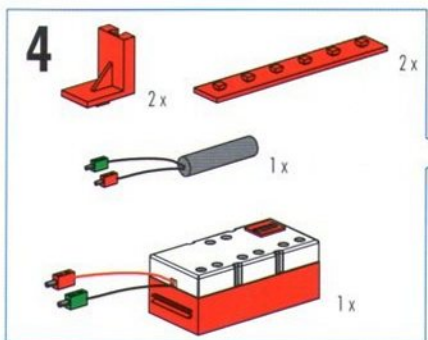
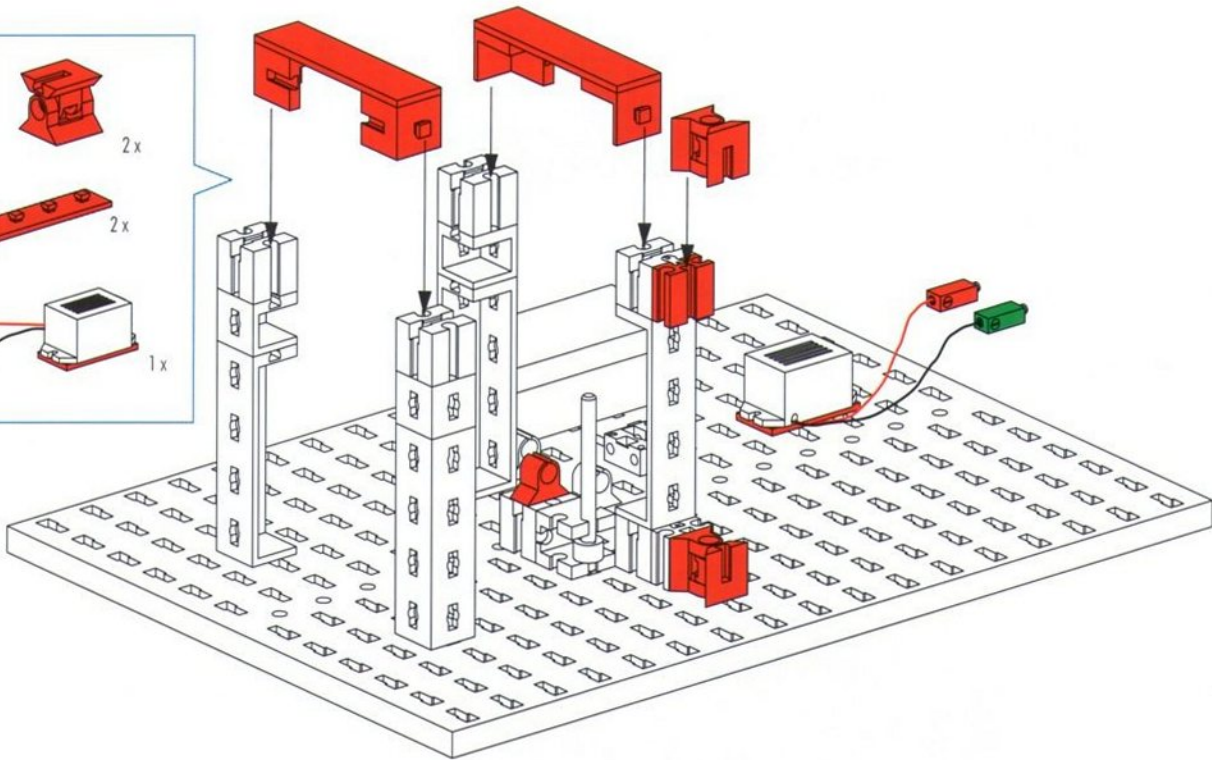
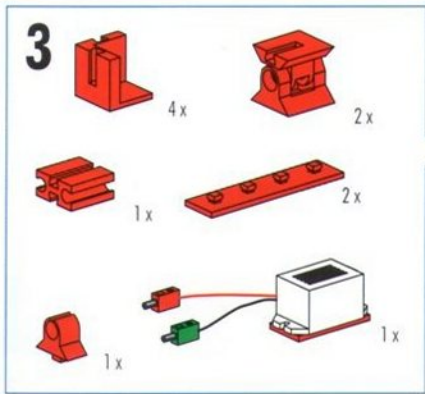

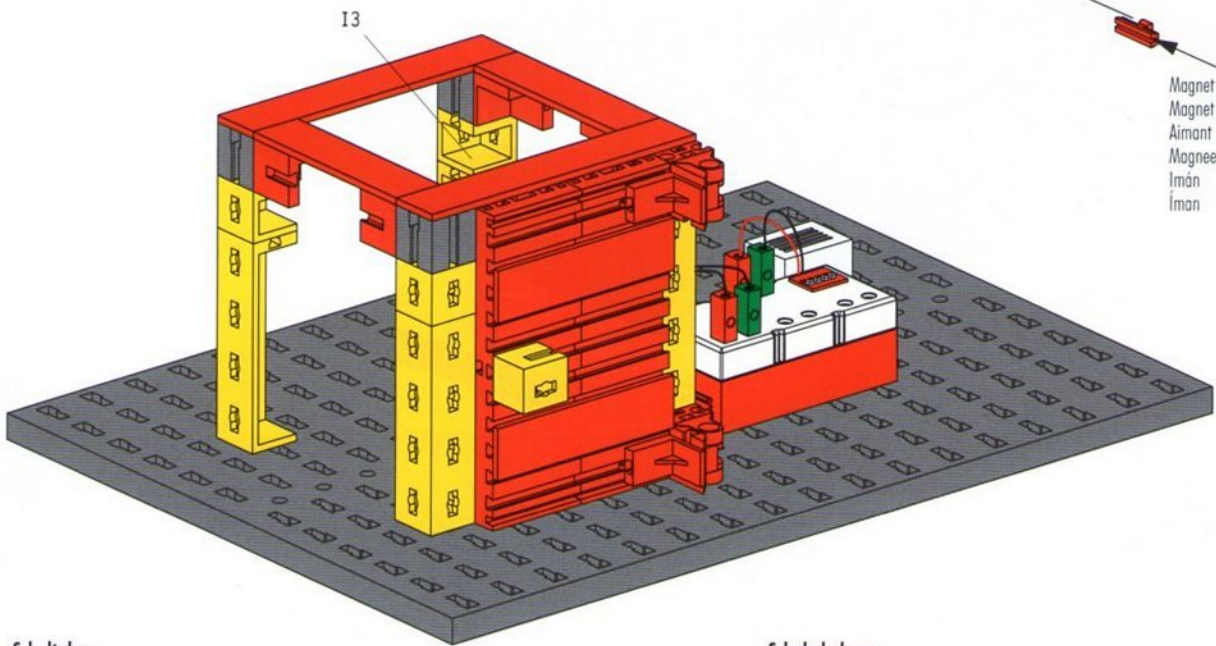
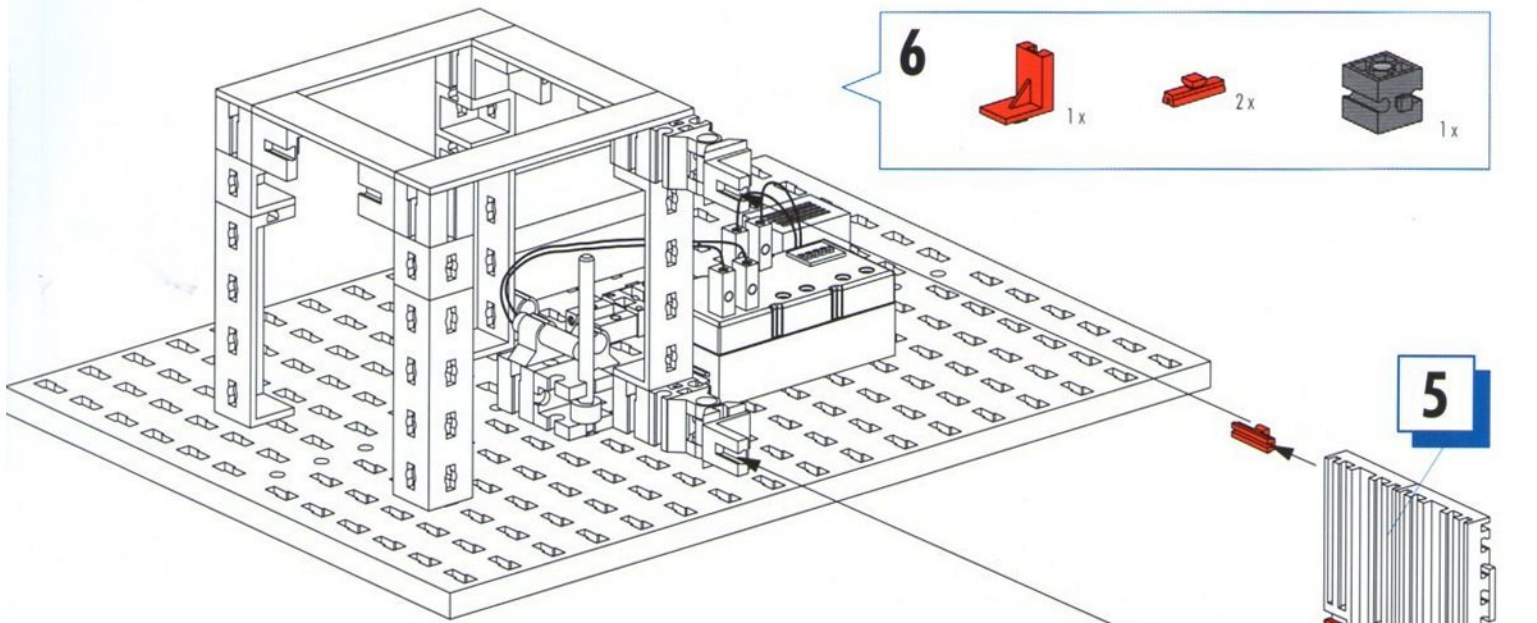

Schaltplan  
Circuit diagram  
Plan électrique

Schakelschema  
Diagrama de circuitos  
Plano elétrico de ligação

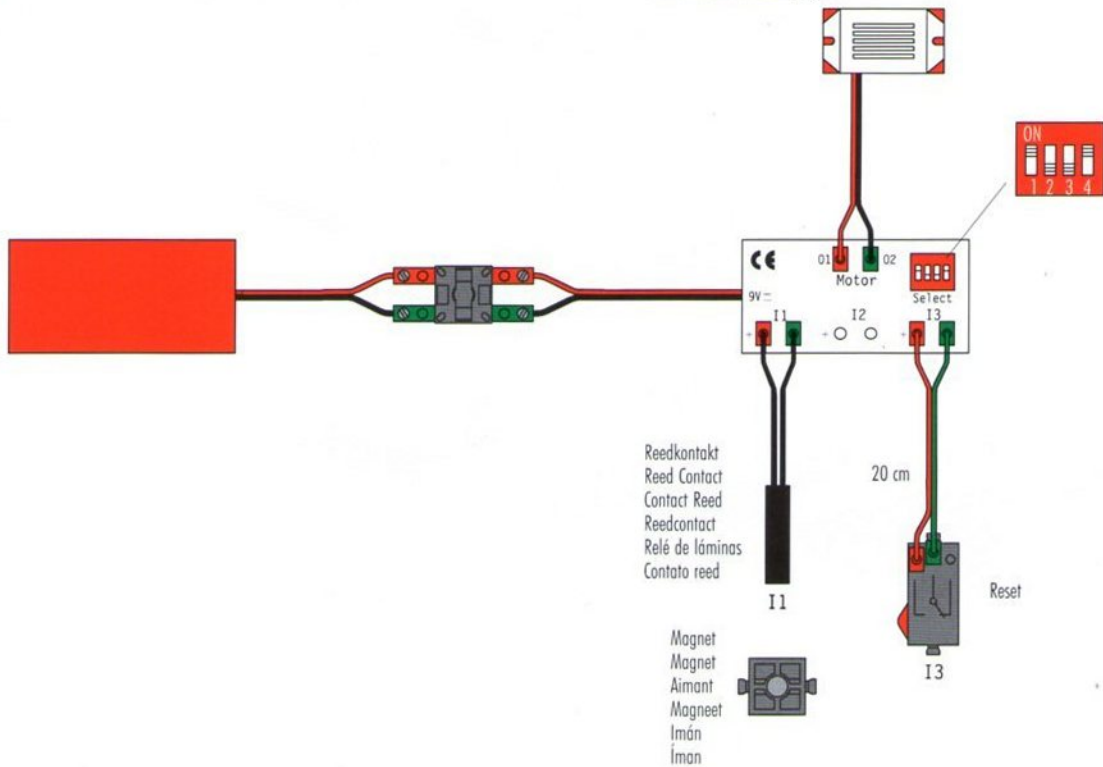



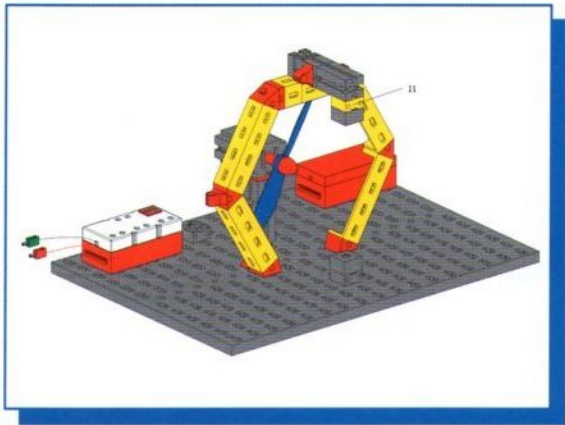

**Händetrockner**  
**Hand dryer**  
**Sèche-mains**

**Handendroger**  
**Secamanos**  
**Secador de mãos**

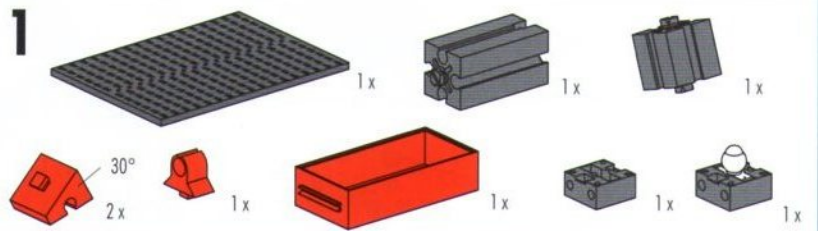

Linsenlampe  
 Lens tip lamp  
 Ampoule lentille  
 Lenslampje  
 Lampada lenticolare  
 Lămpoda de formatu lenticular

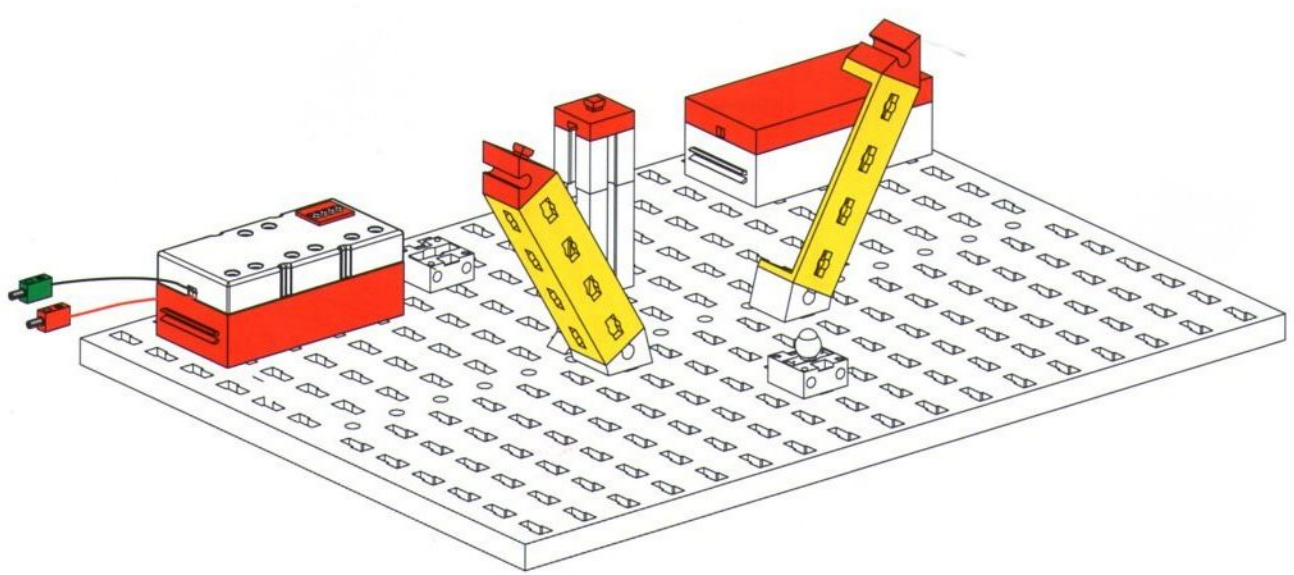
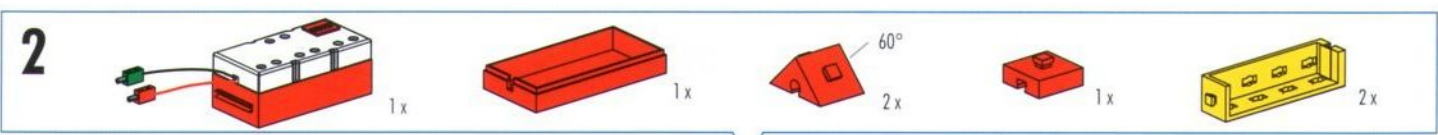
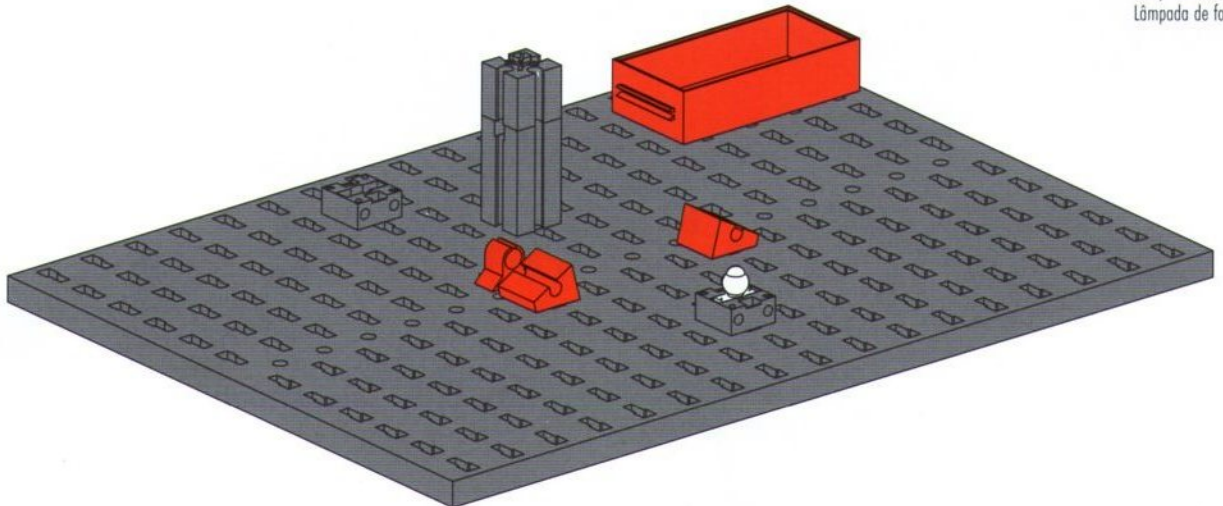



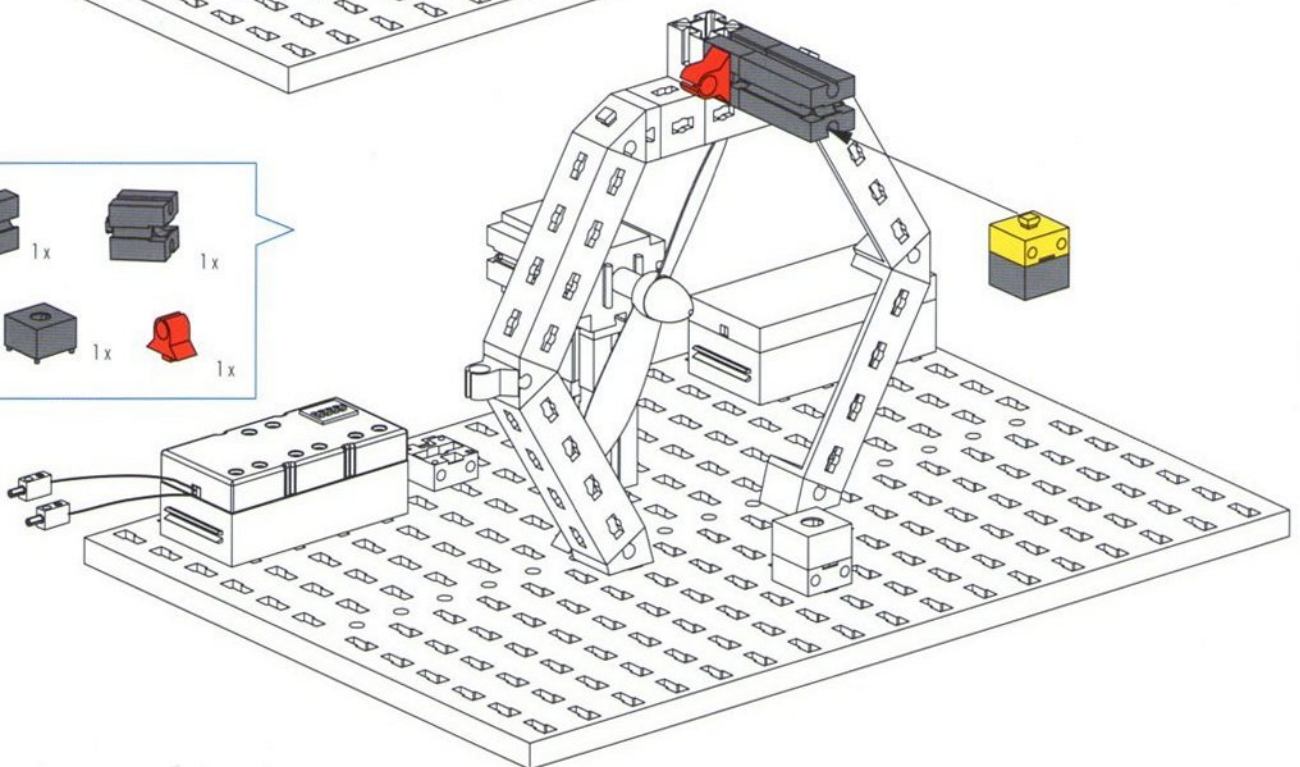
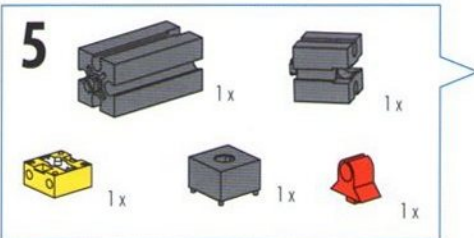
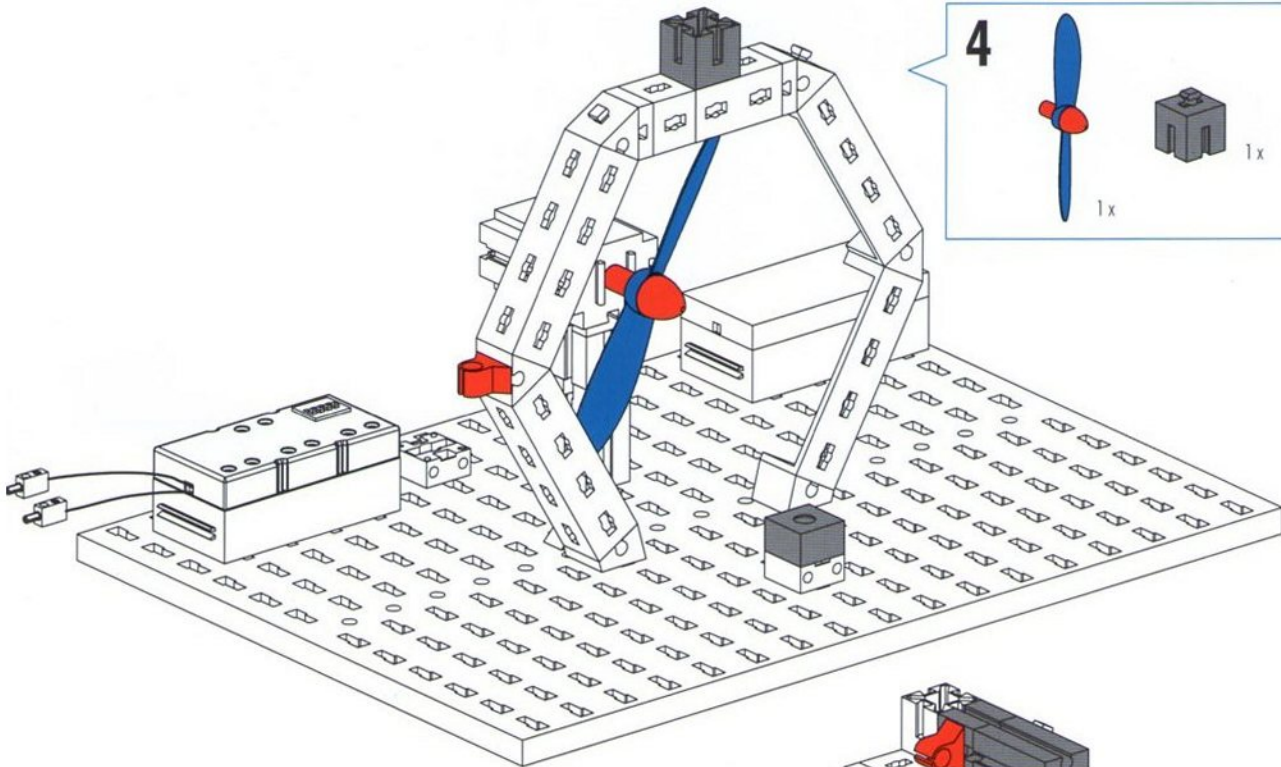
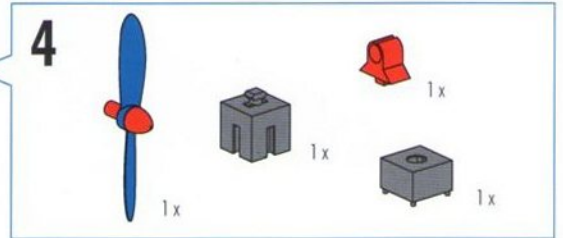
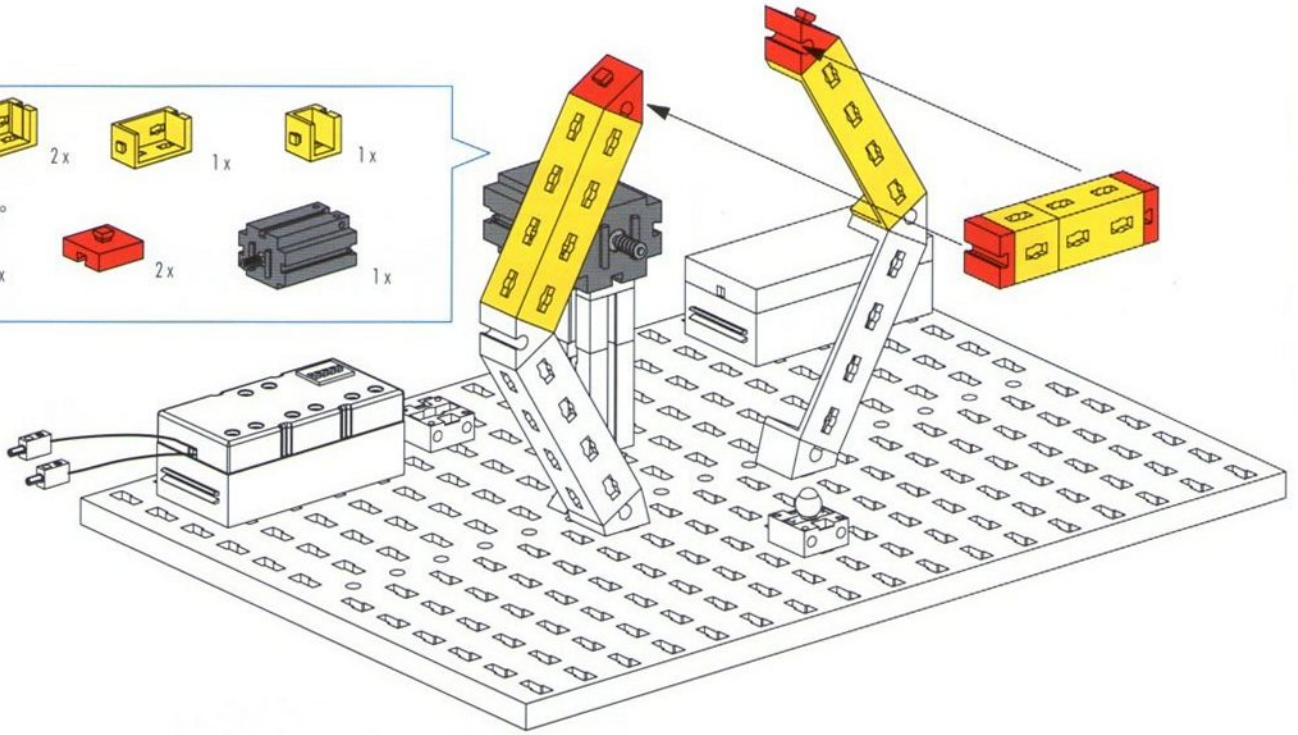
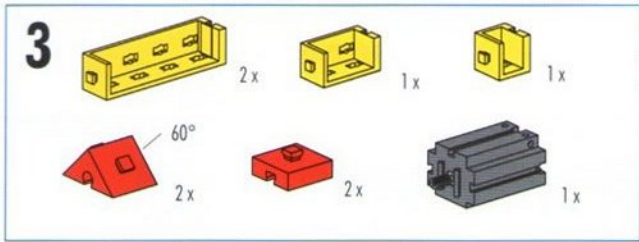



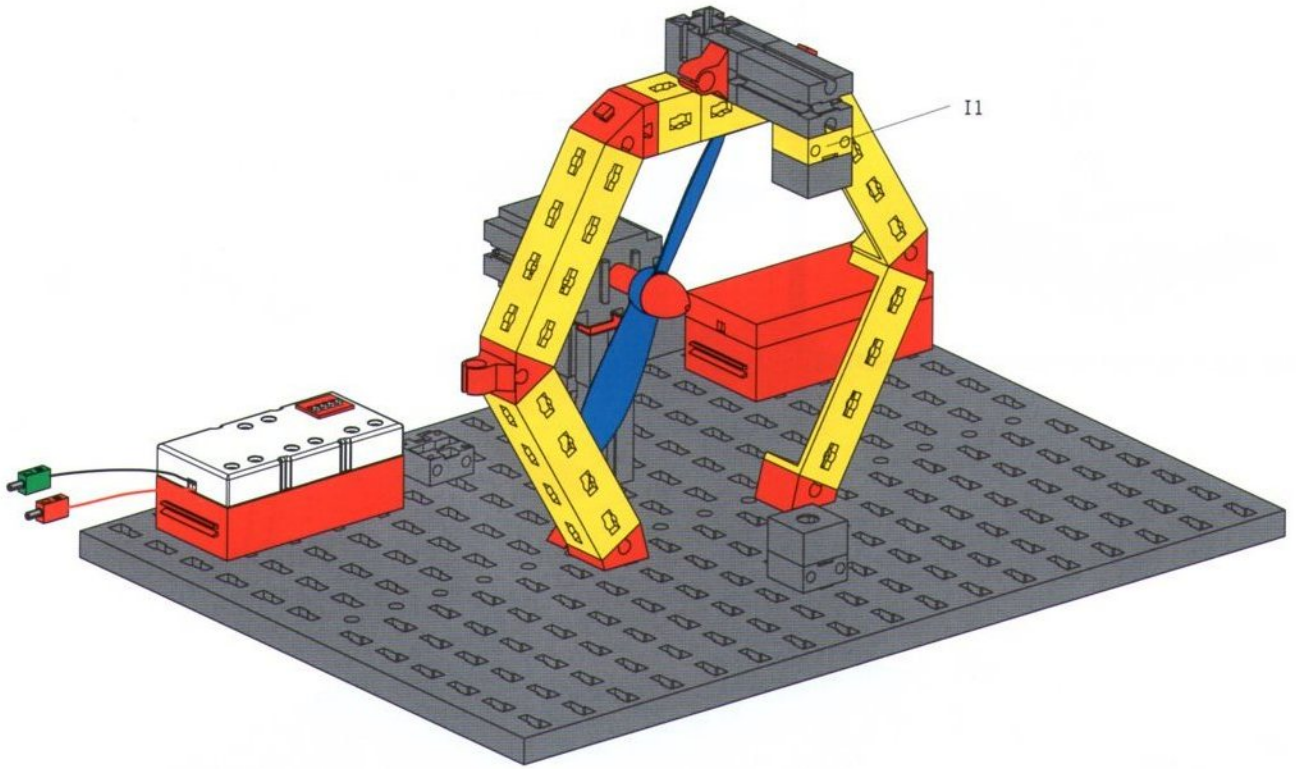

Schaltplan  
Circuit diagram  
Plan électrique

Schakelschema  
Diagrama de circuitos  
Plano elétrico de ligação

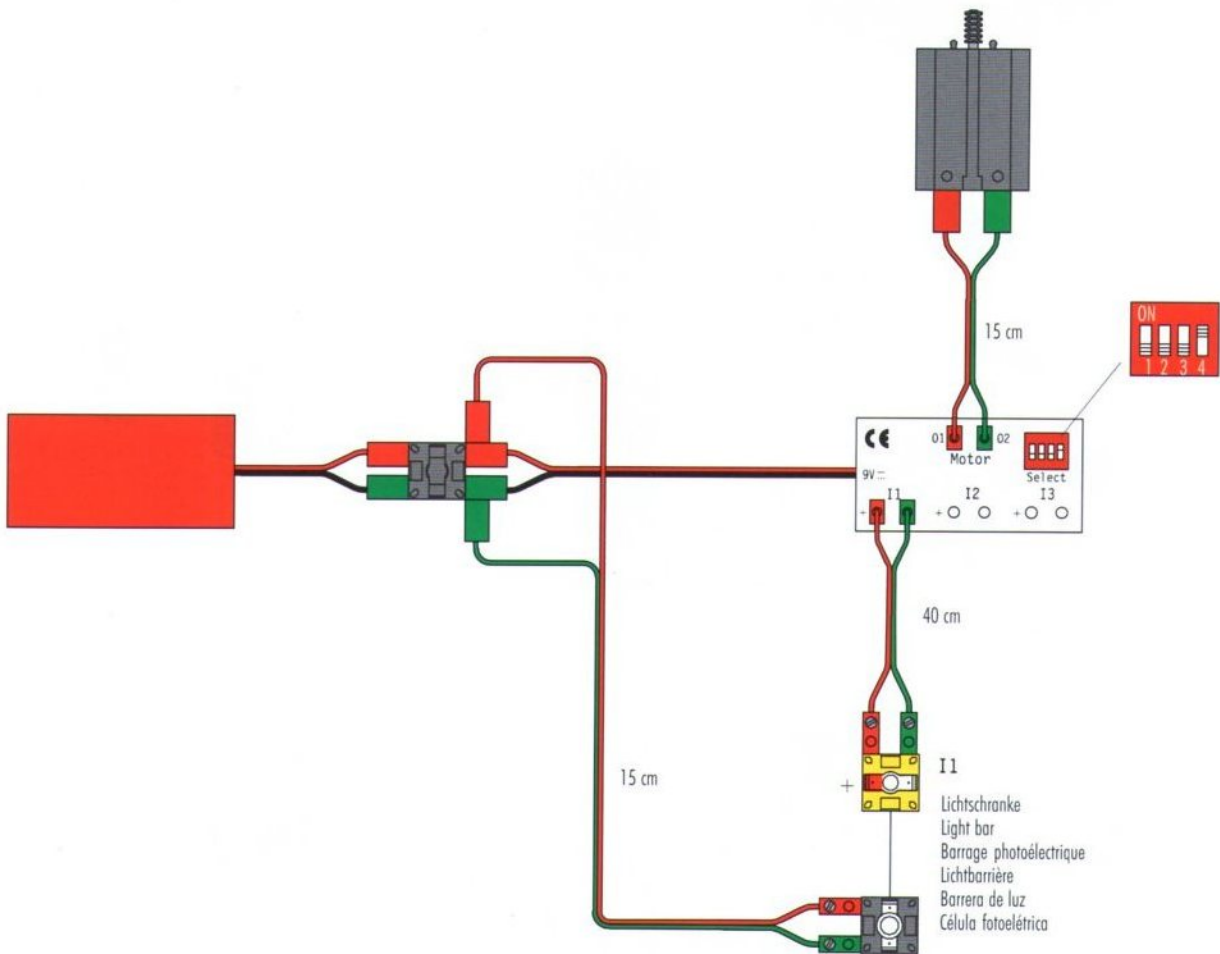



**Stanzmaschine**  
**Punching machine**  
**Poinçonneuse**



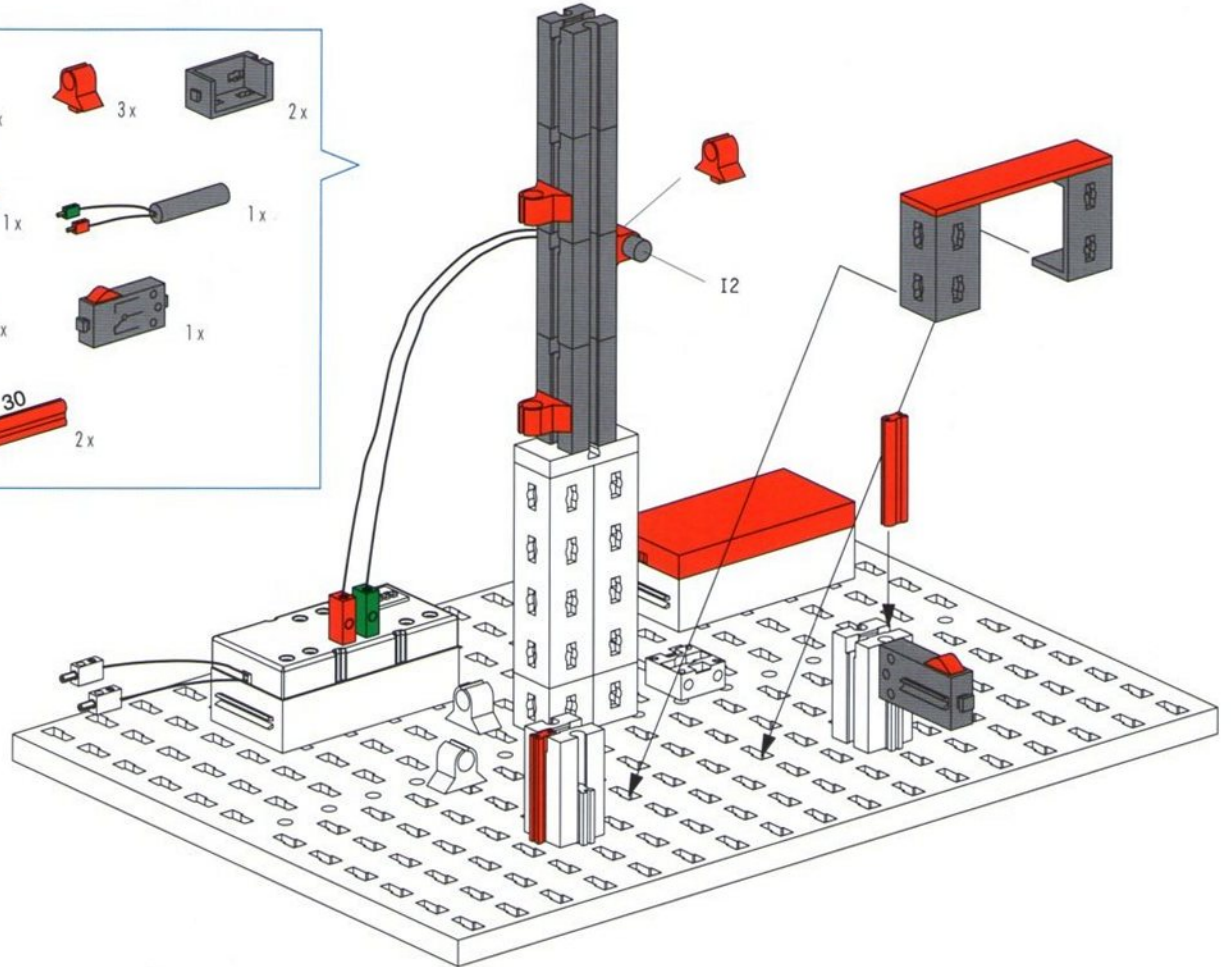
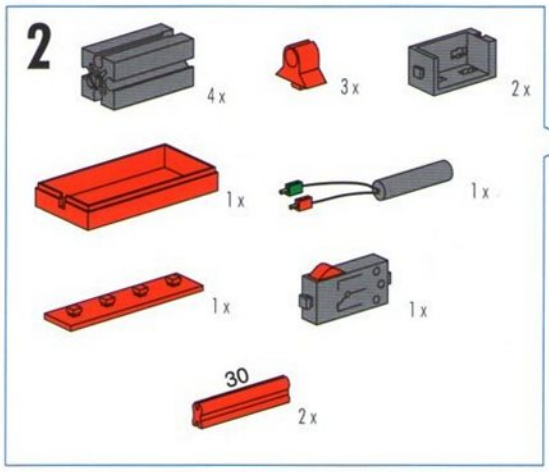
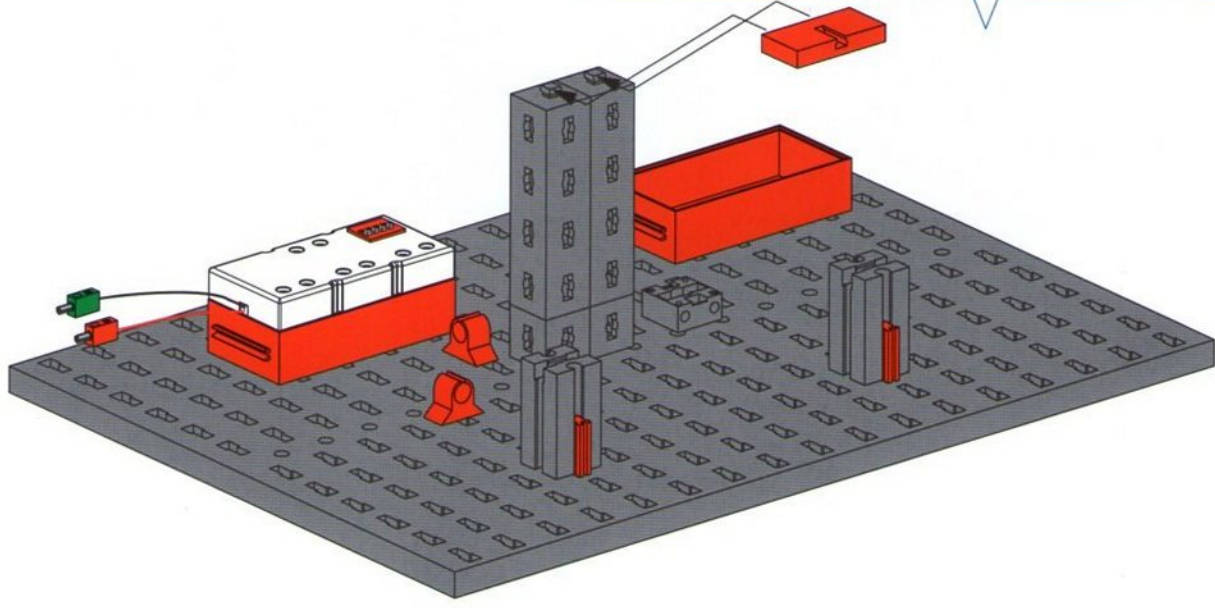
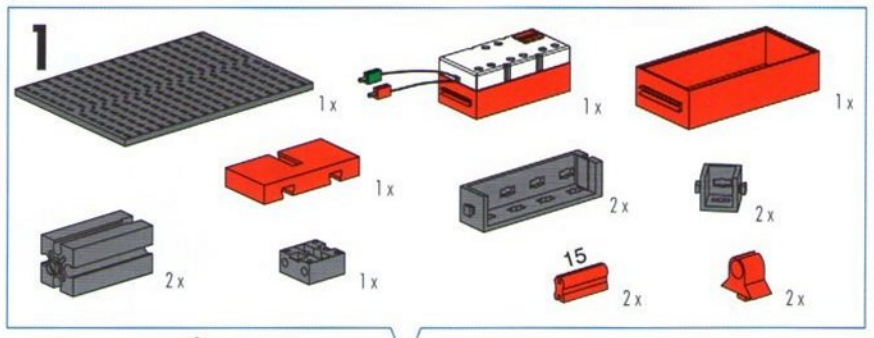

**Stansmaschine**  
**Punzonadora**  
**Máquina de puncionar**

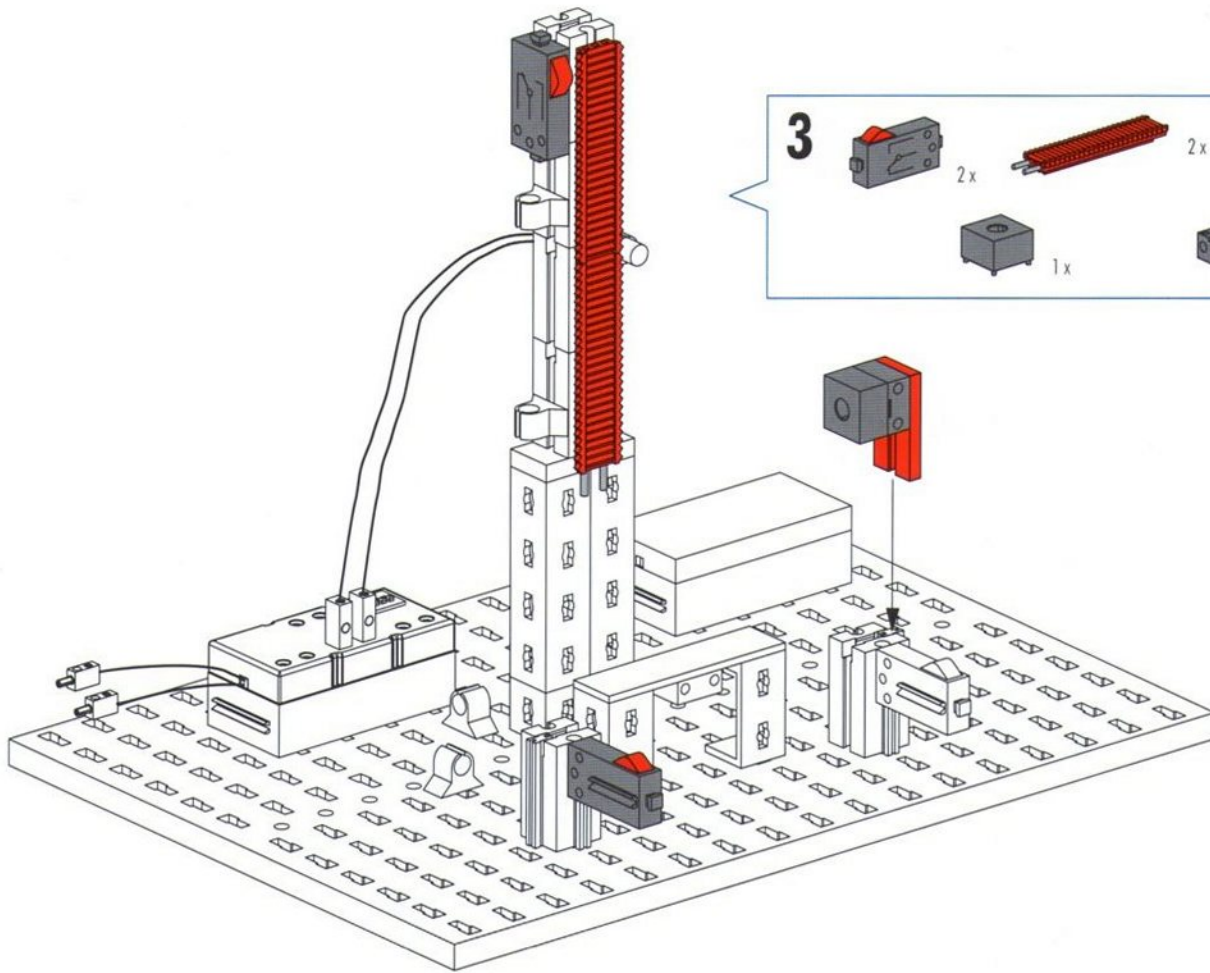









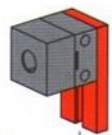

**3**

	2x		2x		1x
	1x		1x		

Linsenlampe  
 Lens tip lamp  
 Ampoule lentille  
 Lenslampje  
 Lampada lenticolare  
 Lâmpada de formató lenticular



**4**

	1x		1x		1x
	1x		1x		1x

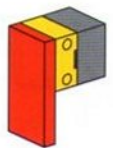
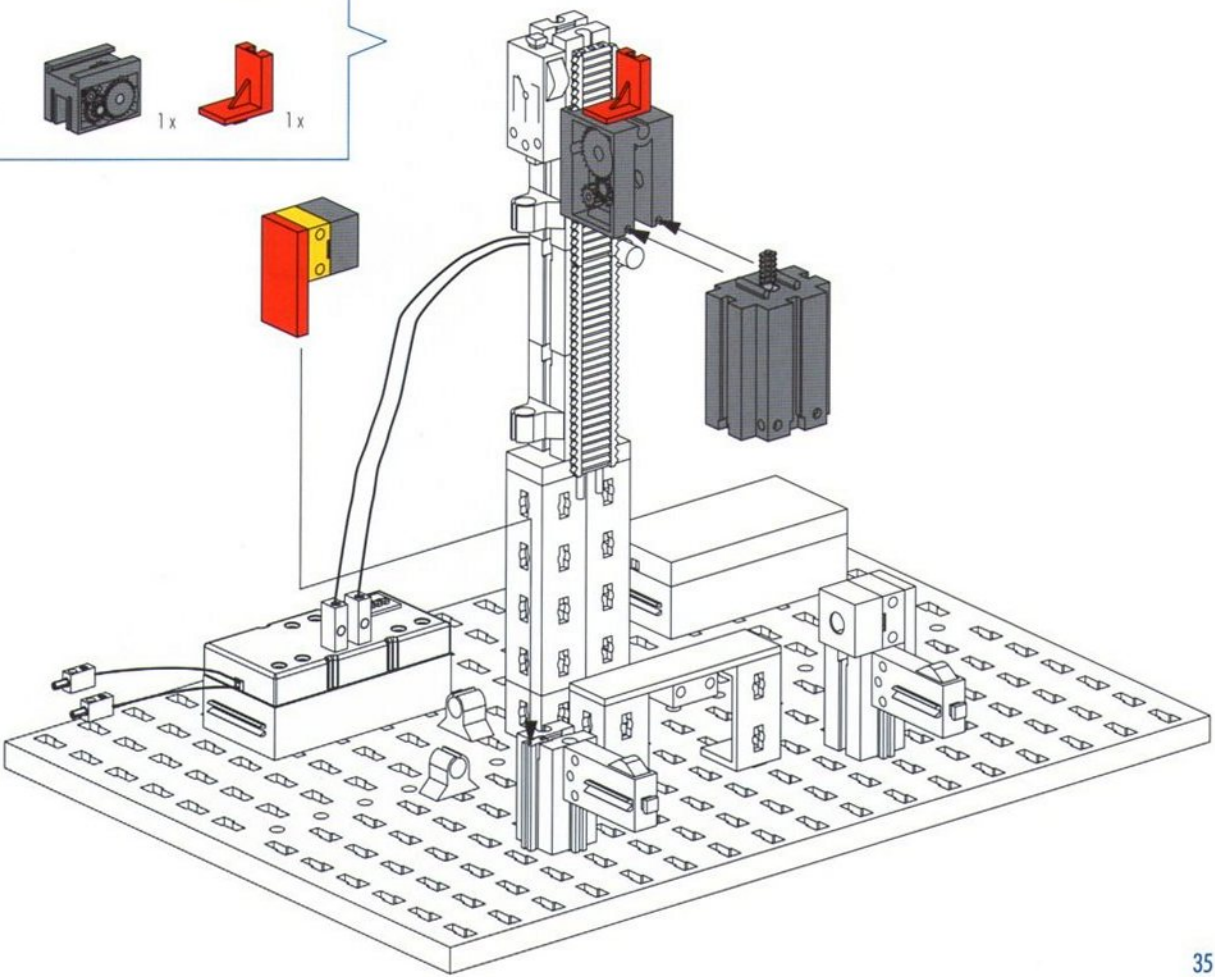

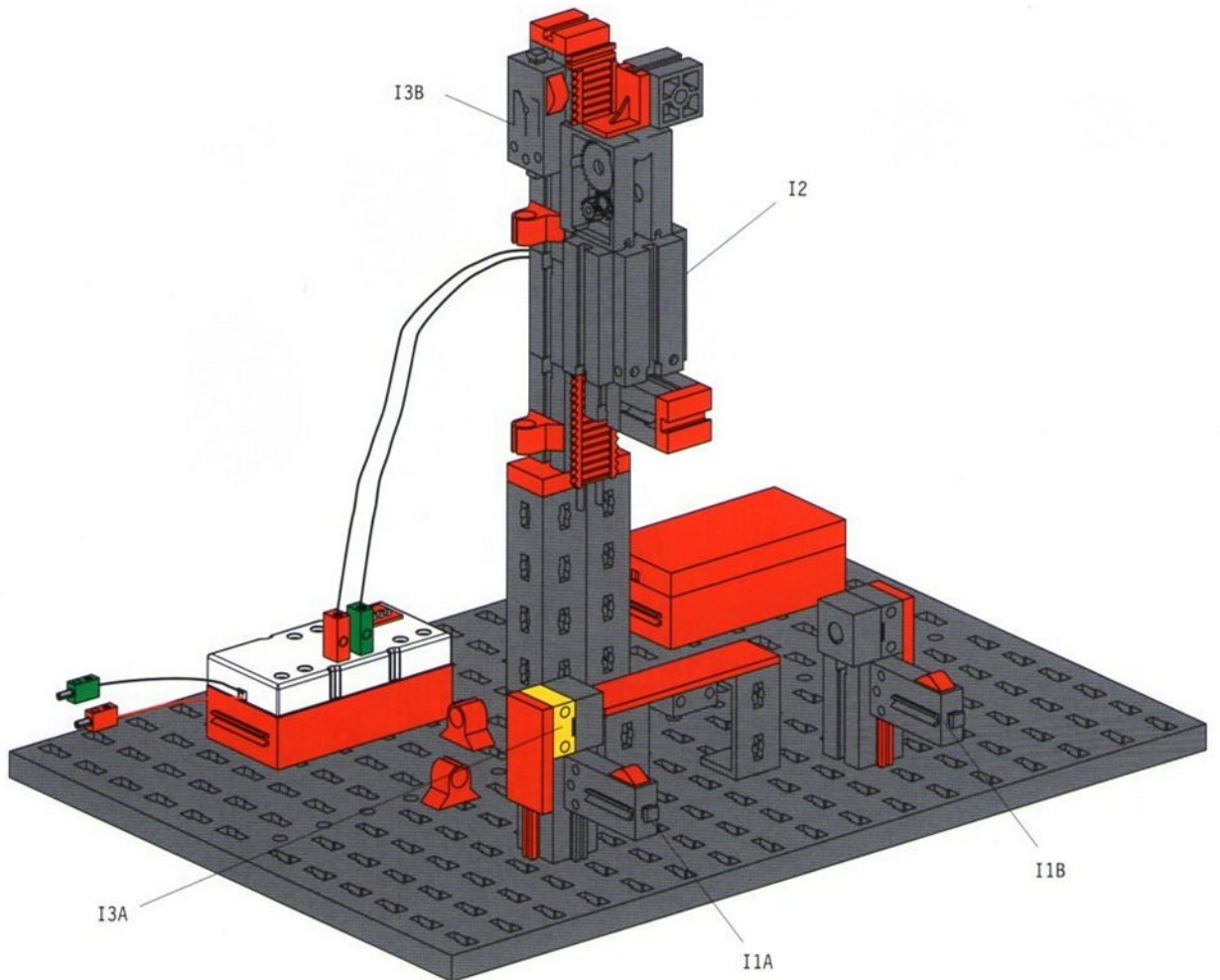
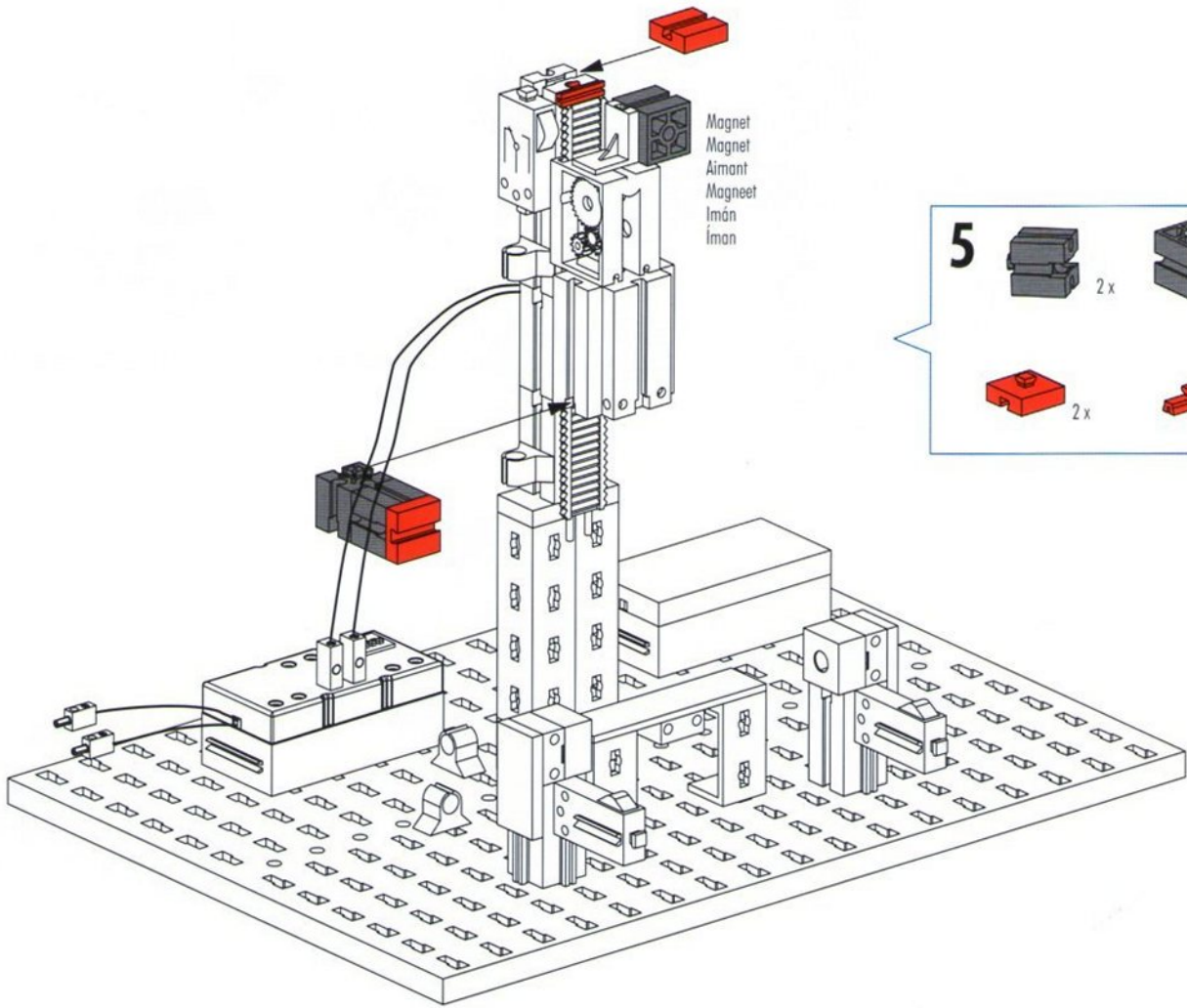



Schaltplan  
Circuit diagram  
Plan électrique

Schakelschema  
Diagrama de circuitos  
Plano elétrico de ligação

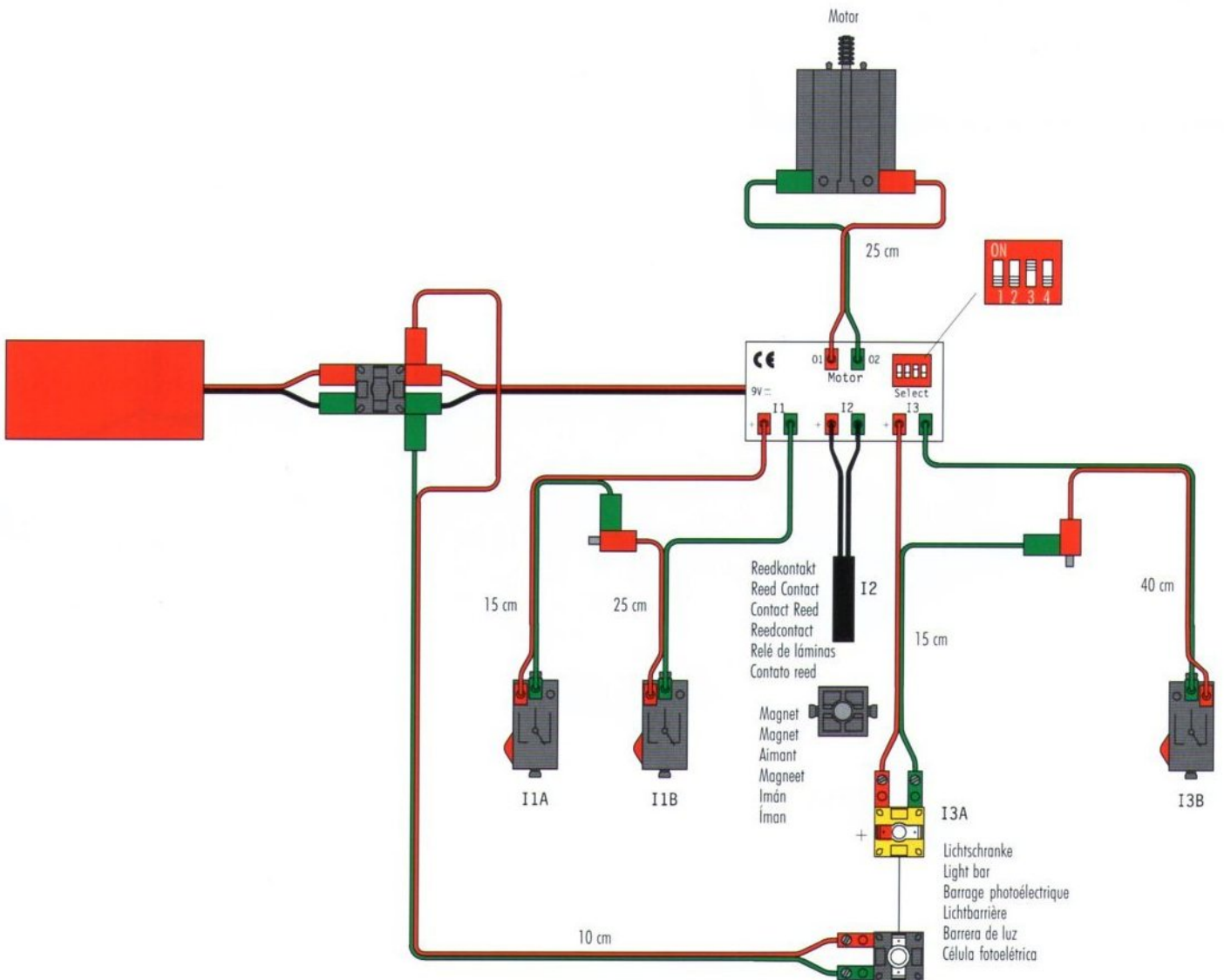

Garagentor  
Garage door  
Porte de garage

Garageur  
Puerta del garaje  
Portão da garagem

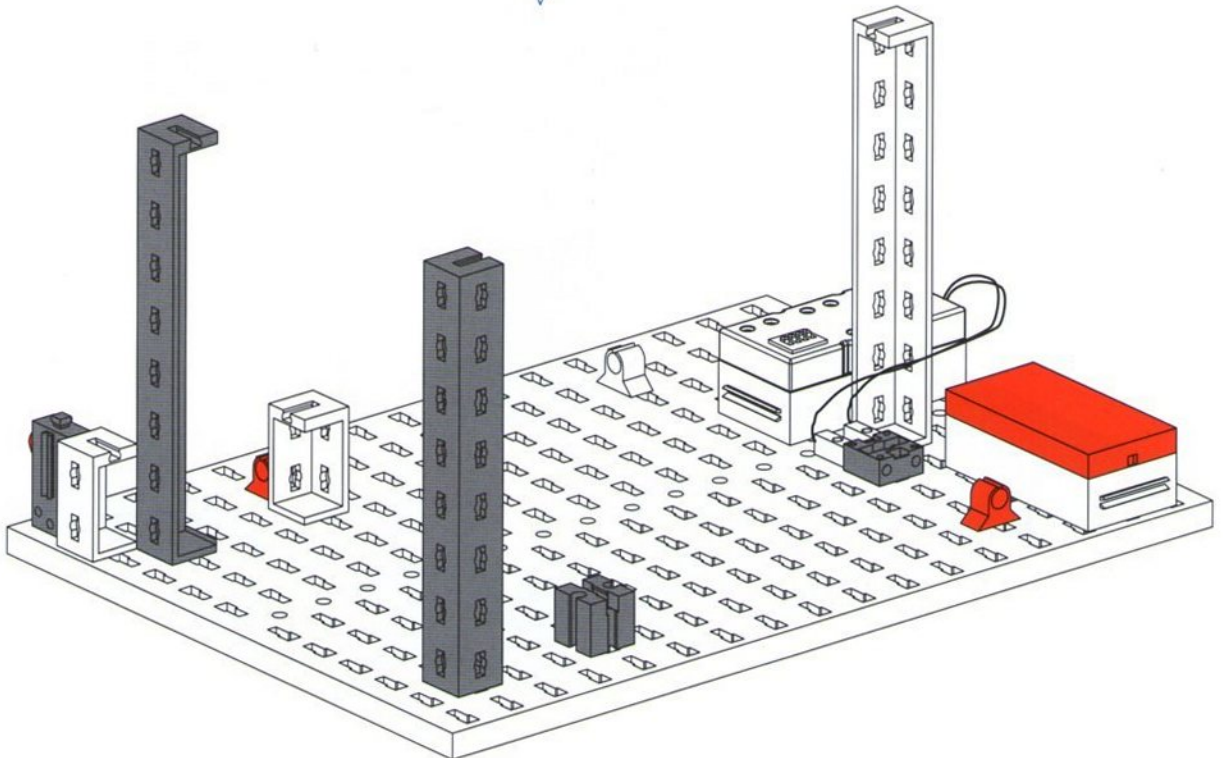
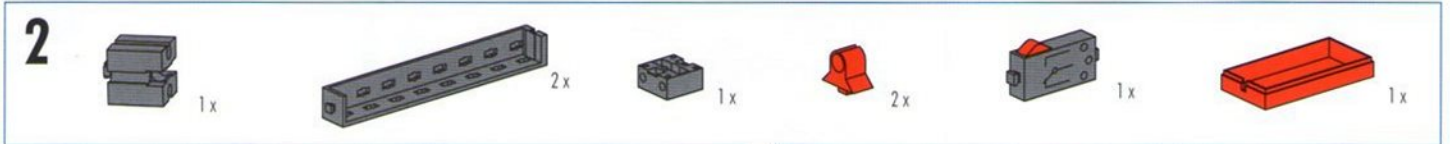
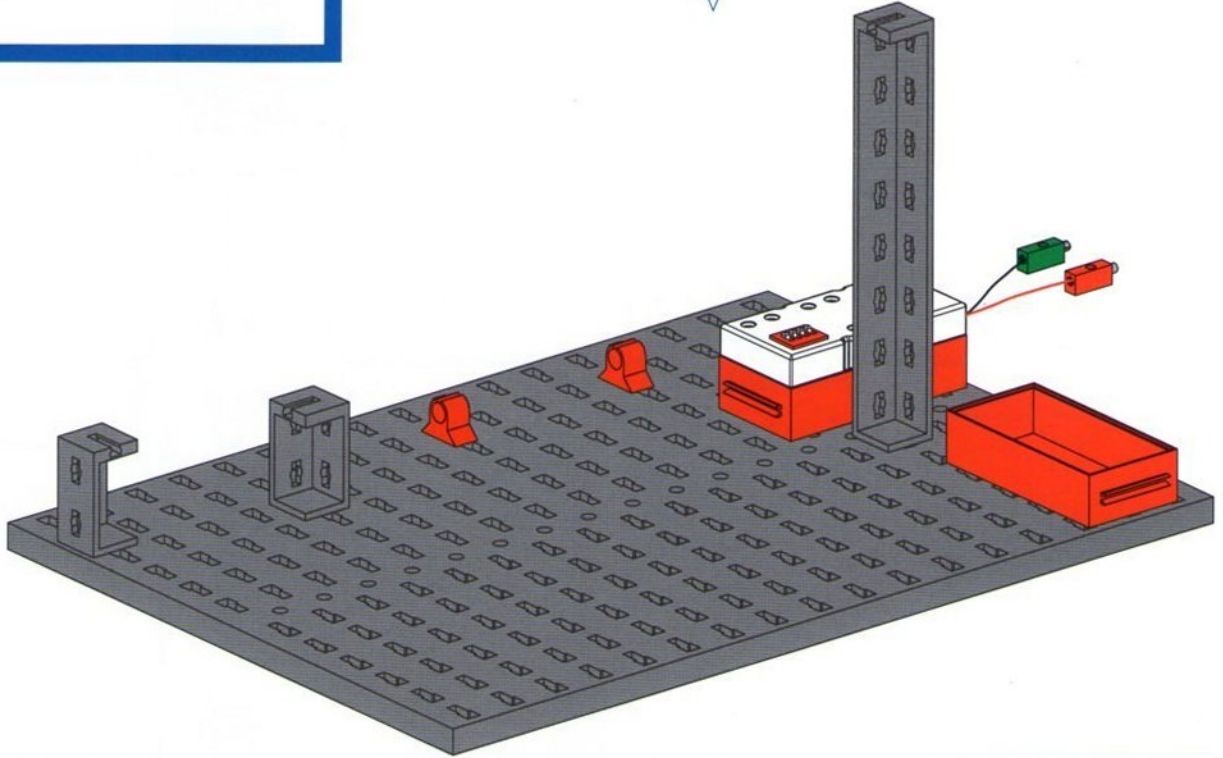
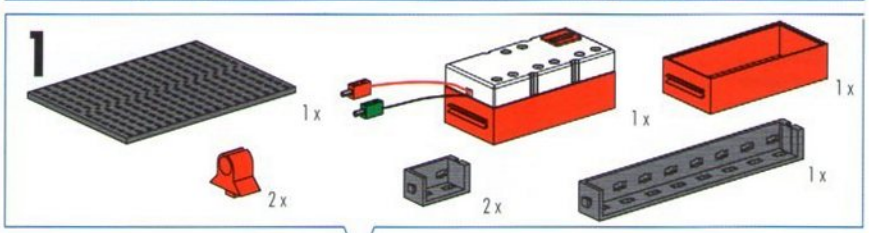



3

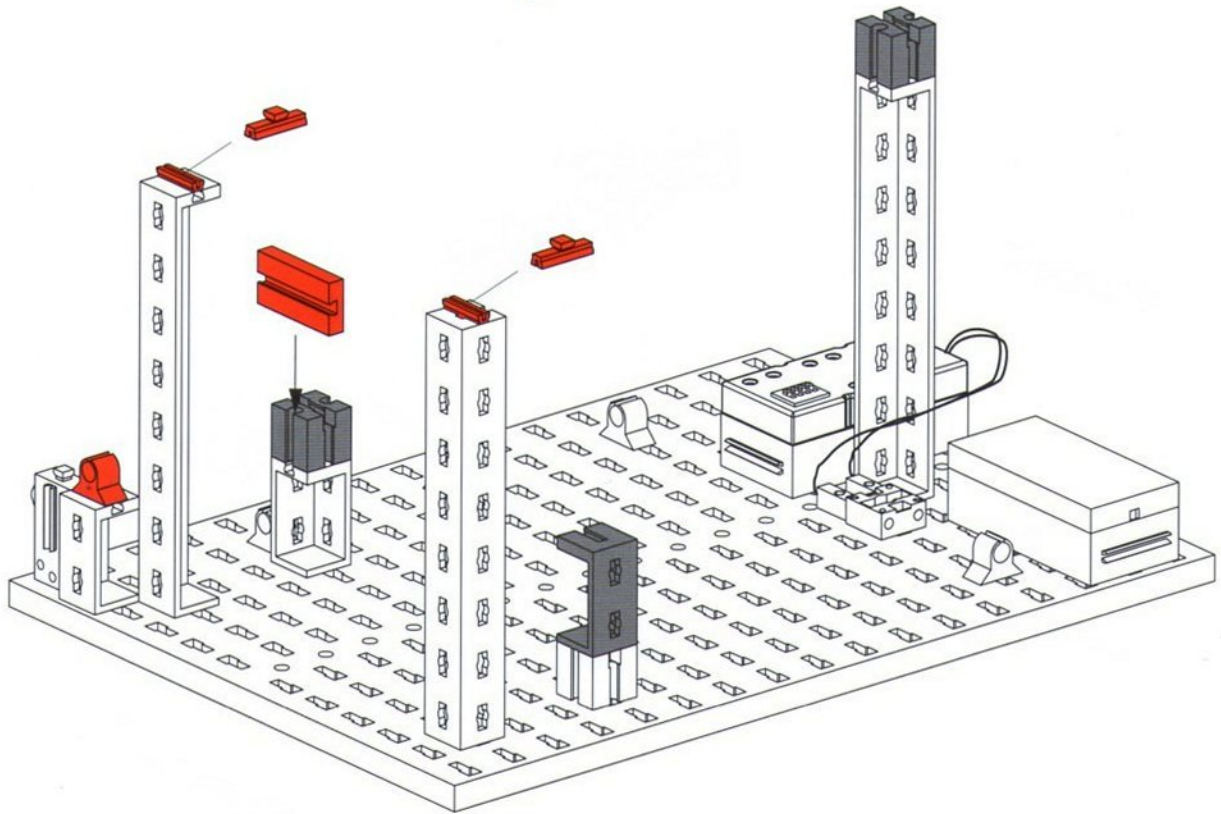

4

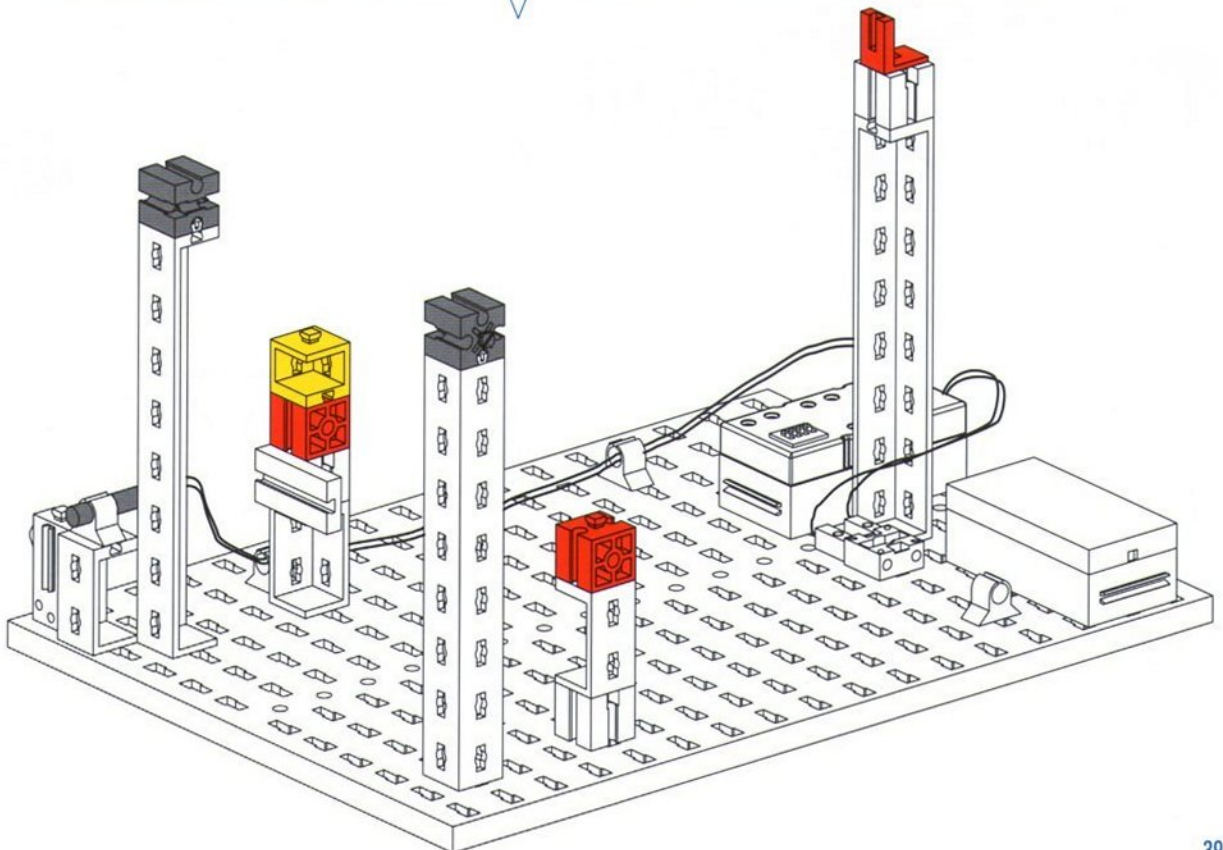

5

- 45 2x
- 4 4x
- 1x
- 1x
- 1x
- 1x

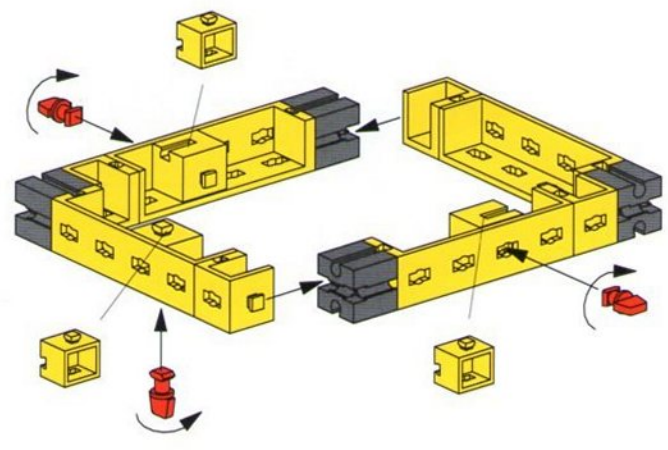
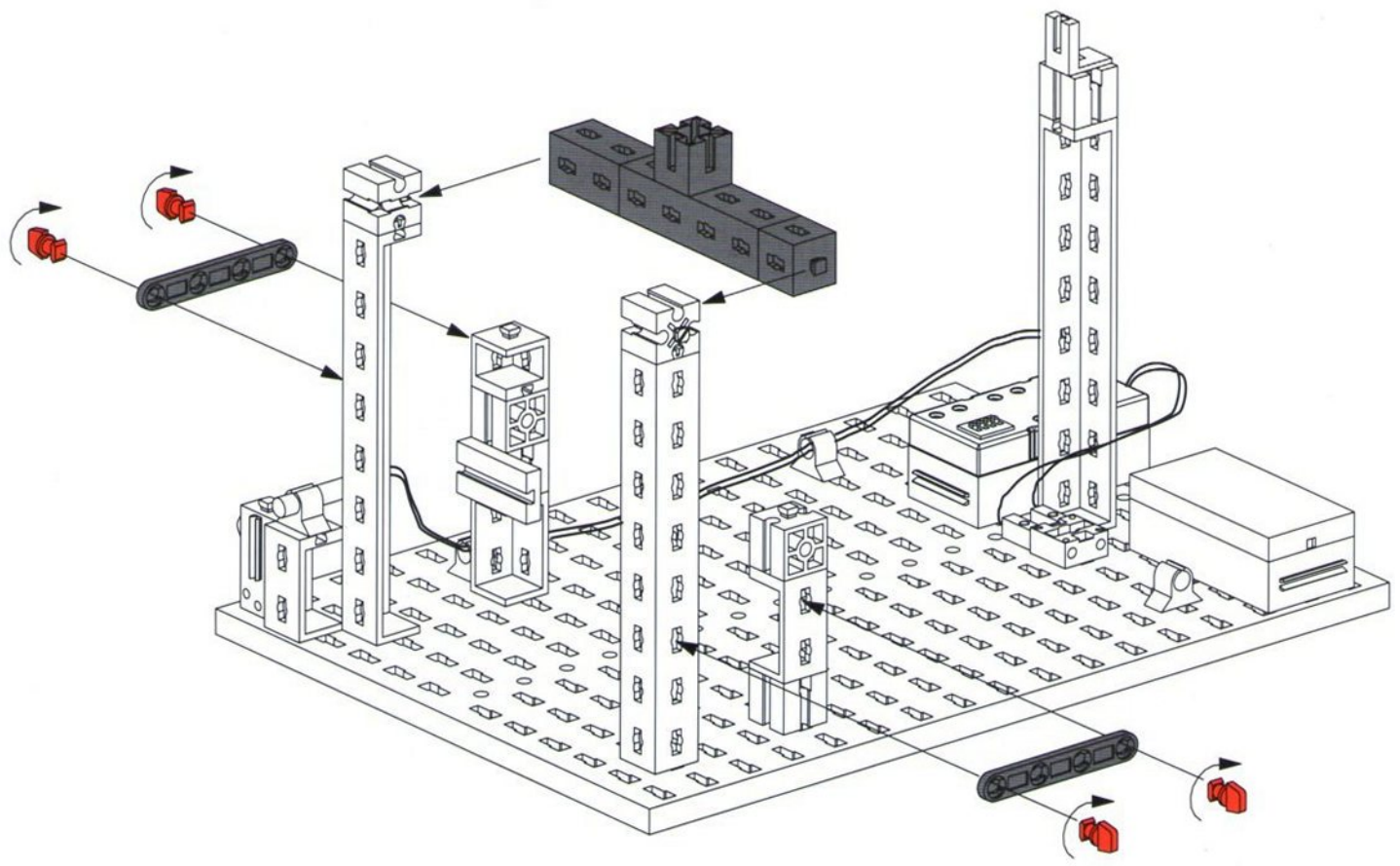

6

- 4x
- 4x
- 3x
- 4 3x
- 4x

- 7
- 1x
  - 2x
  - 1x
  - 2x
  - 2x
  - 1x
  - 50 1x

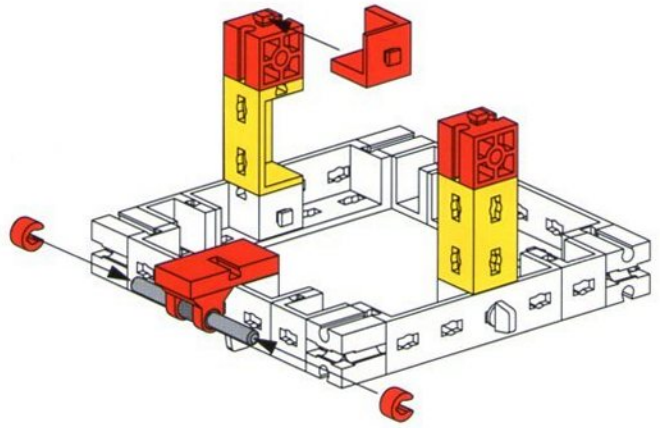

50

Stahlachse · Steel axel · Essieu en acier ·  
 Stalen as · Eje de acero · Eixo de aço



8

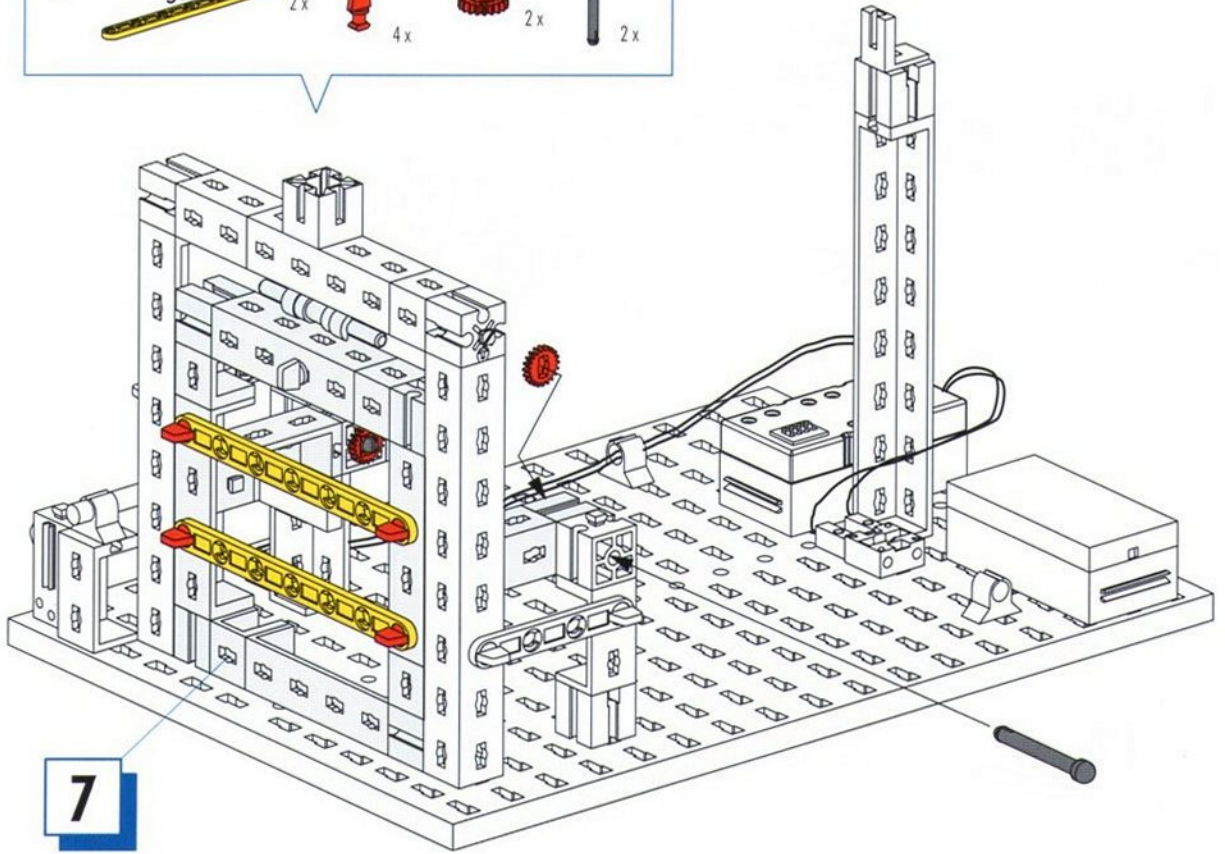
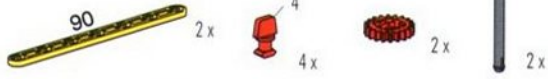

7

9

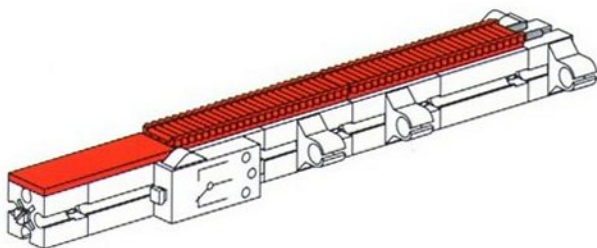
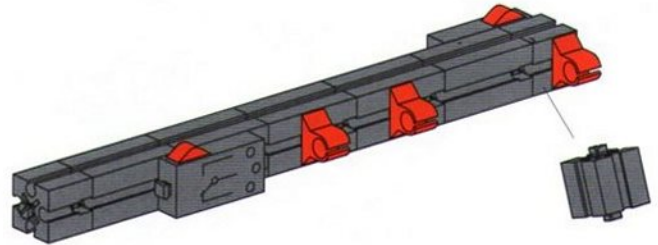
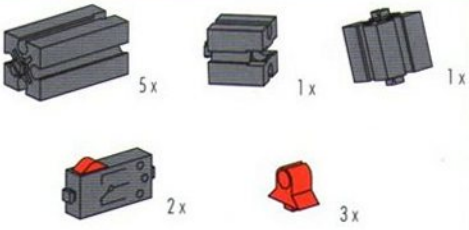

10



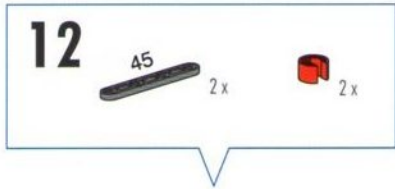
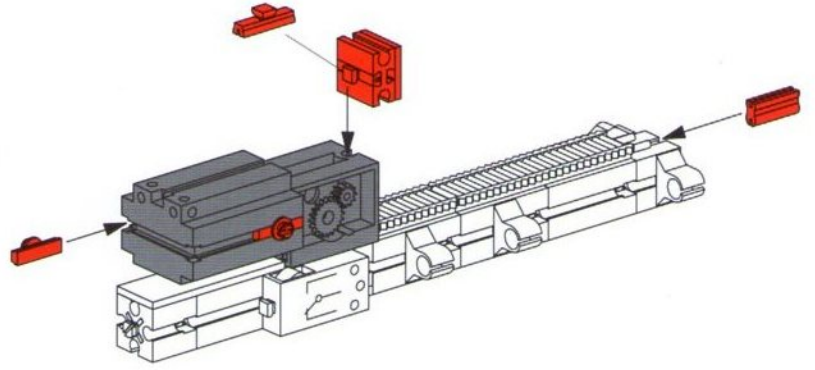
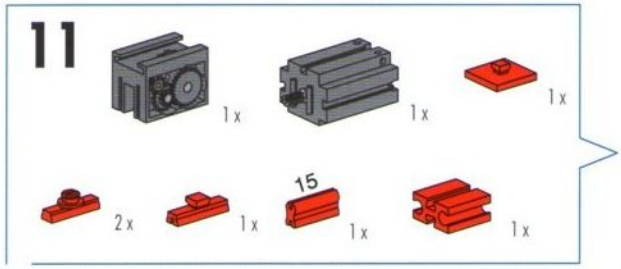

**11**

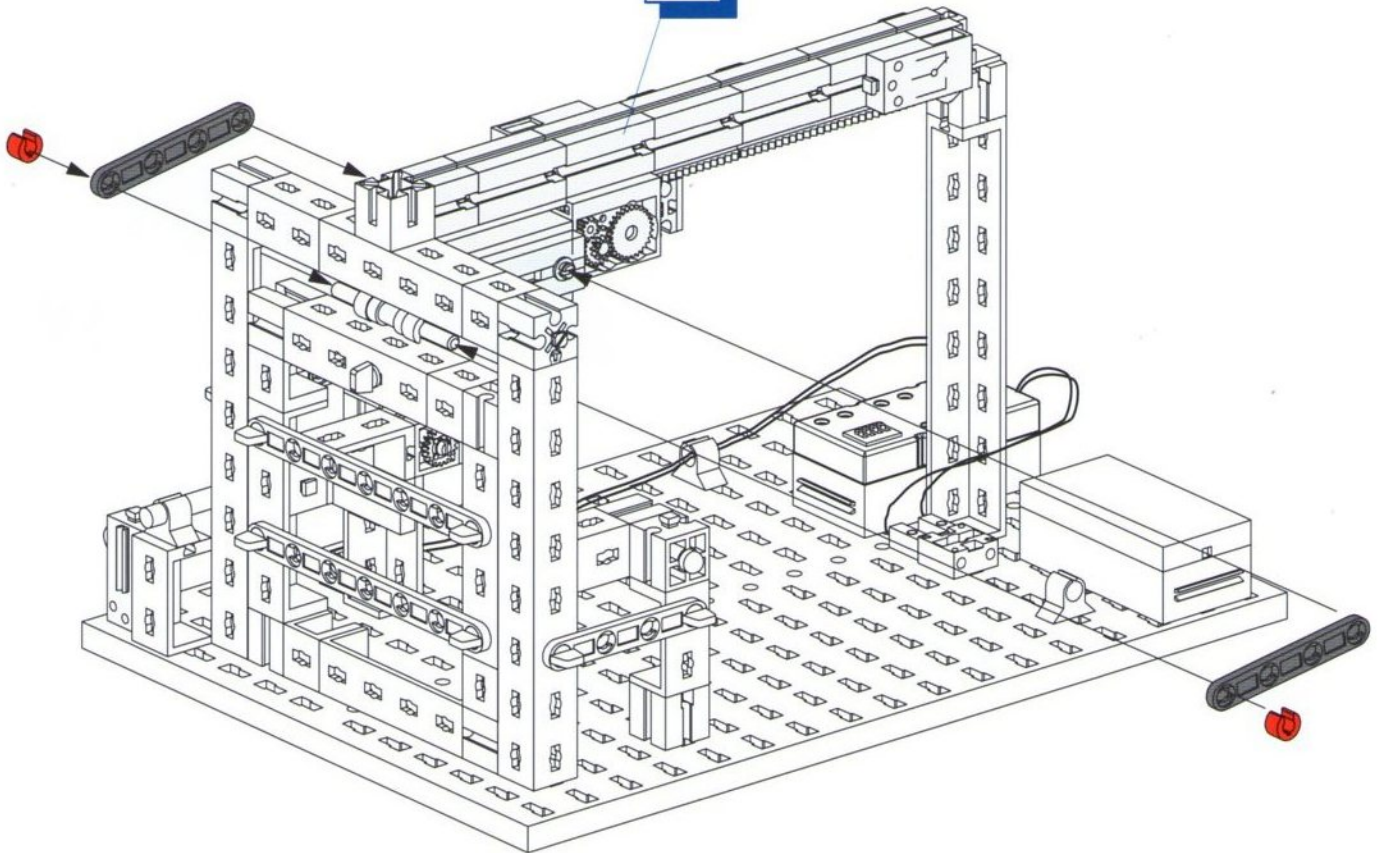



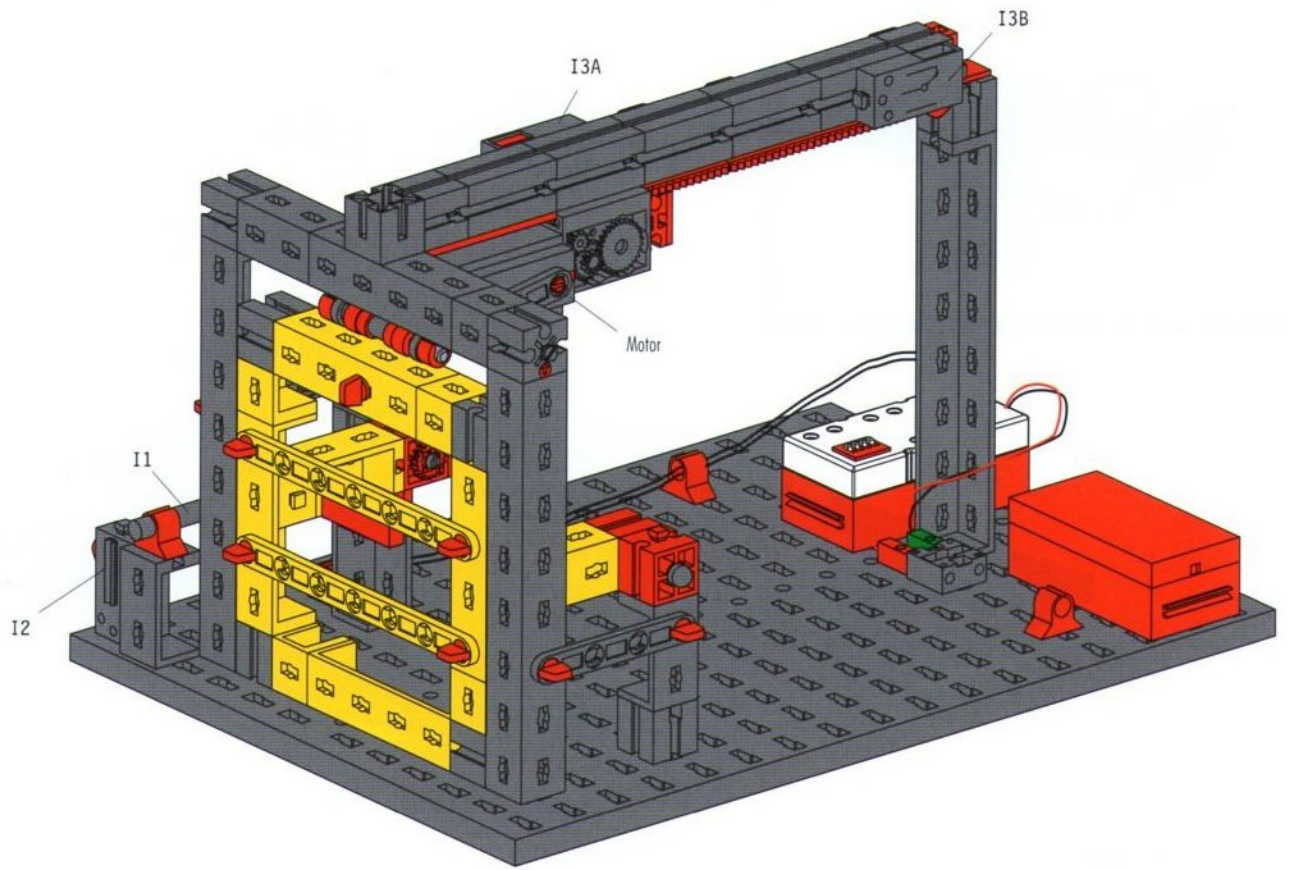

Schaltplan  
Circuit diagram  
Plan électrique

Schakelschema  
Diagrama de circuitos  
Plano eléctrico de ligação

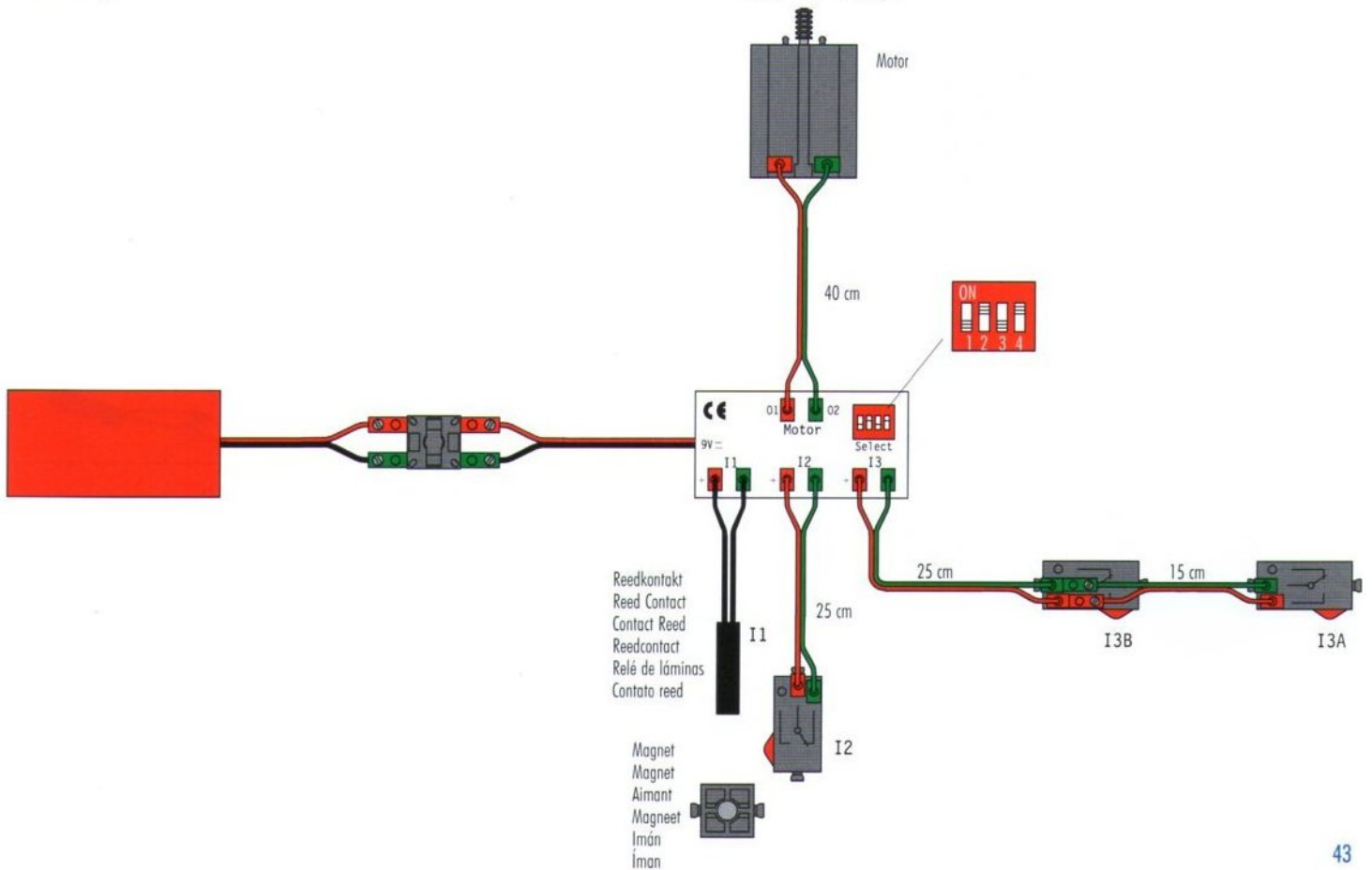

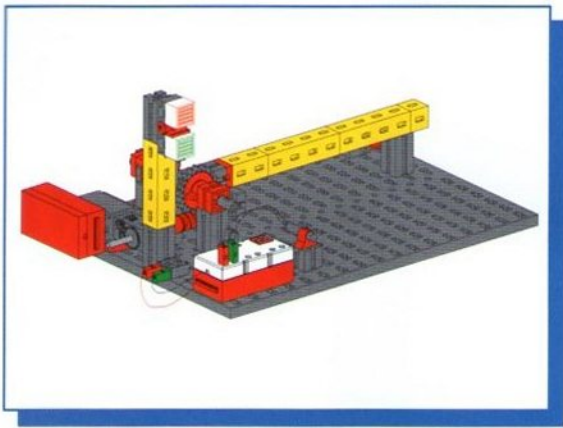

**Parkhausschranke**  
**Barrier of a public garage**  
**Barrière de parking**

**Slagboom aan de parkeergarage**  
**Barrera del aparcamiento**  
**Barreiras do silo-auto**

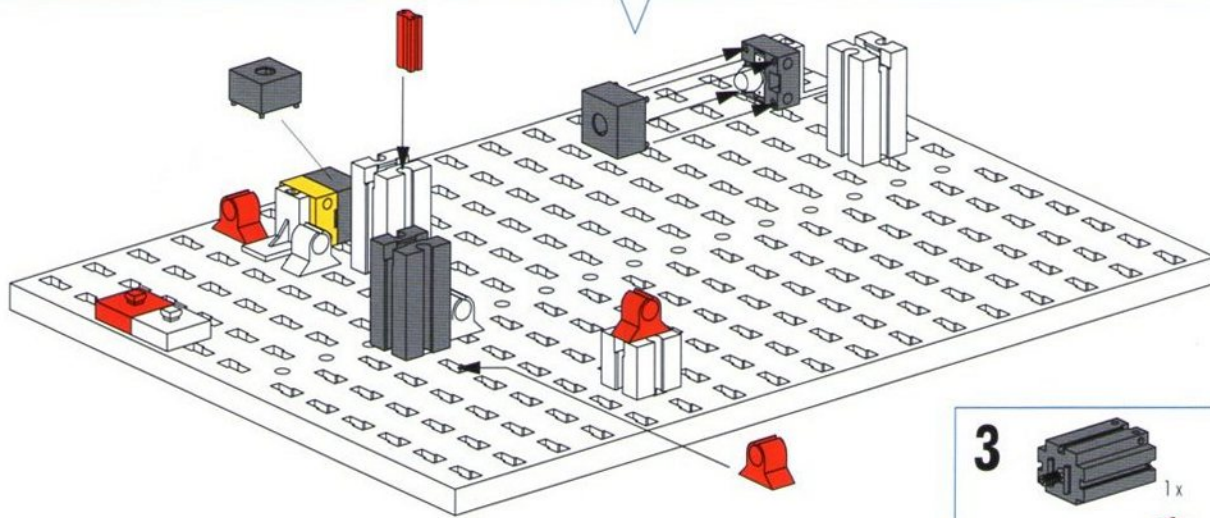
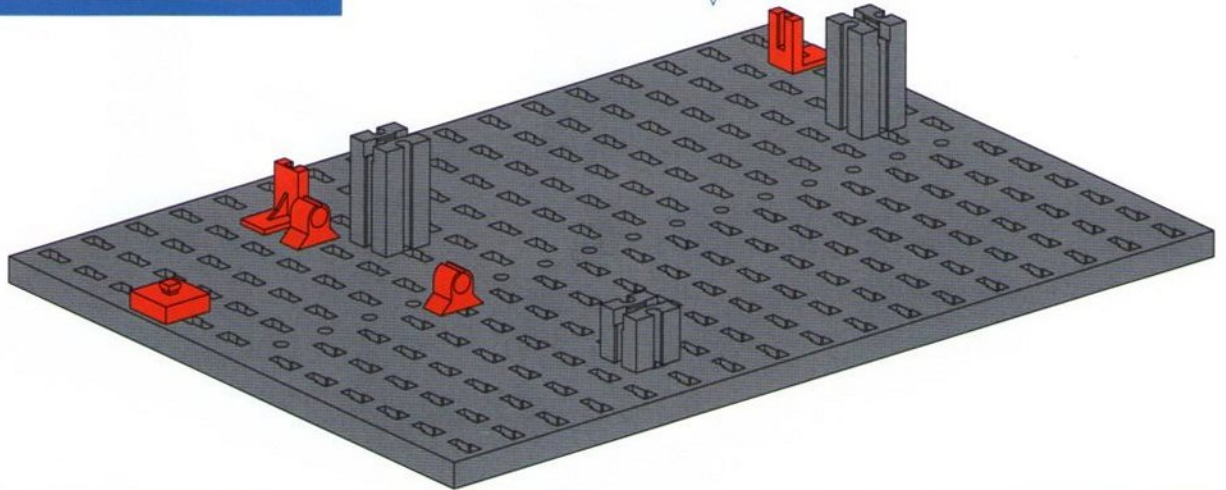
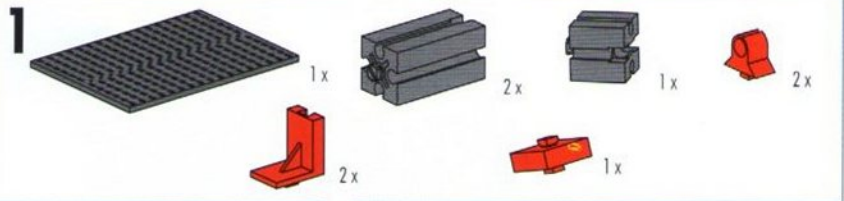

Linsenlampe  
 Lens tip lamp  
 Ampoule lentille  
 Lenslampje  
 Lampada lenticolare  
 Lâmpada de formato lenticular

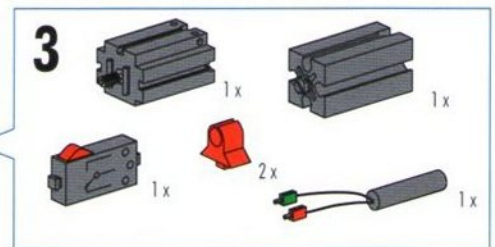
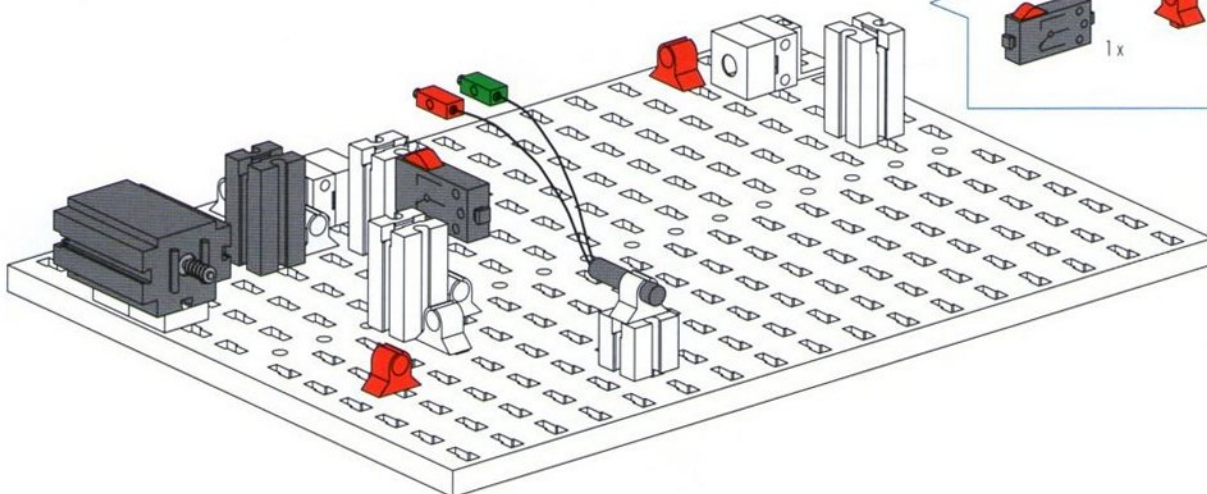



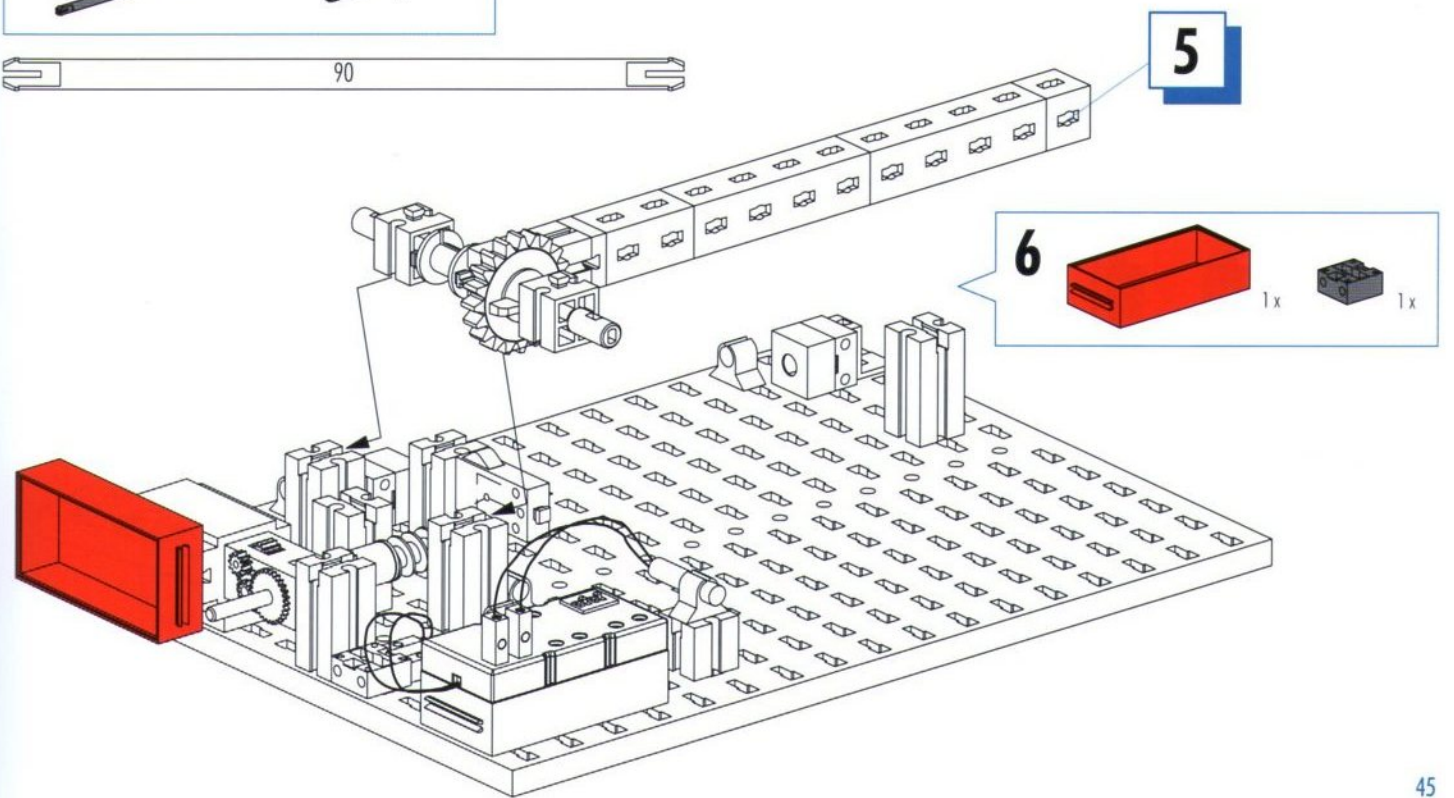
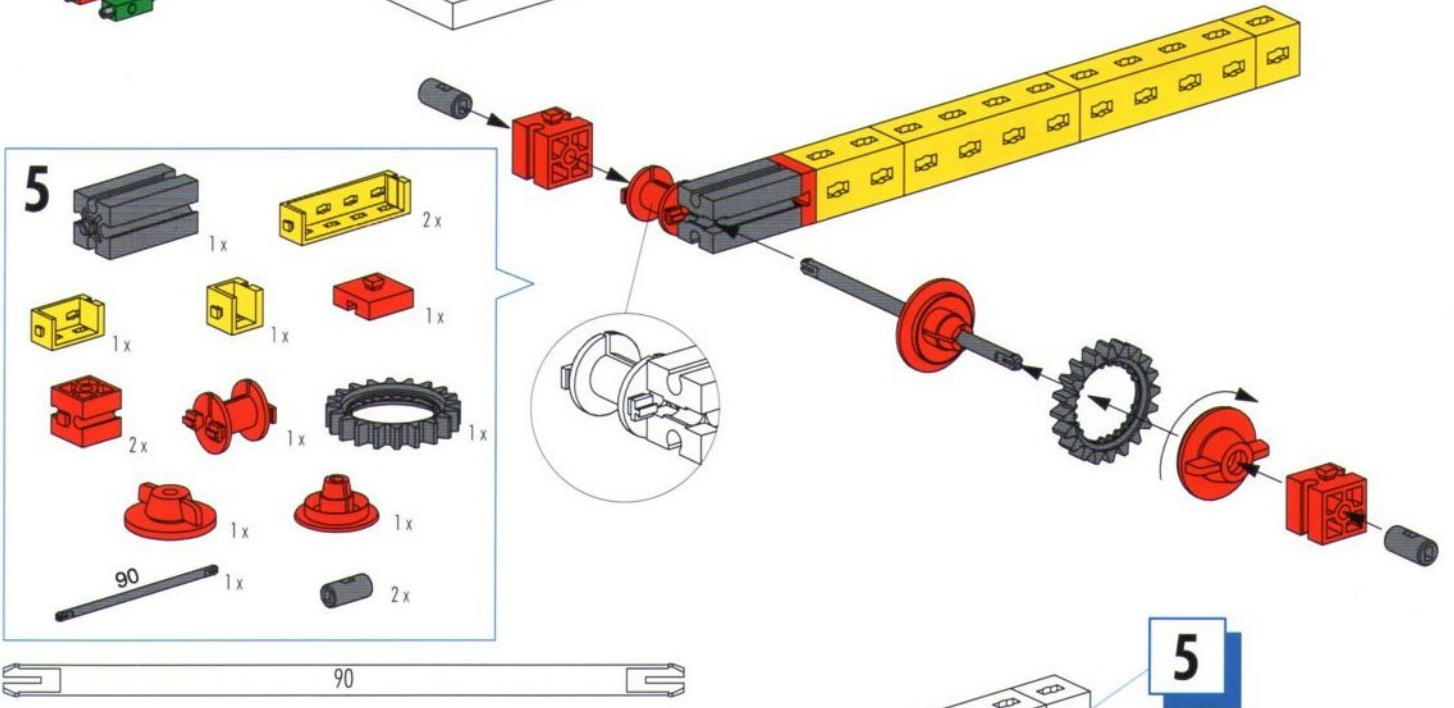
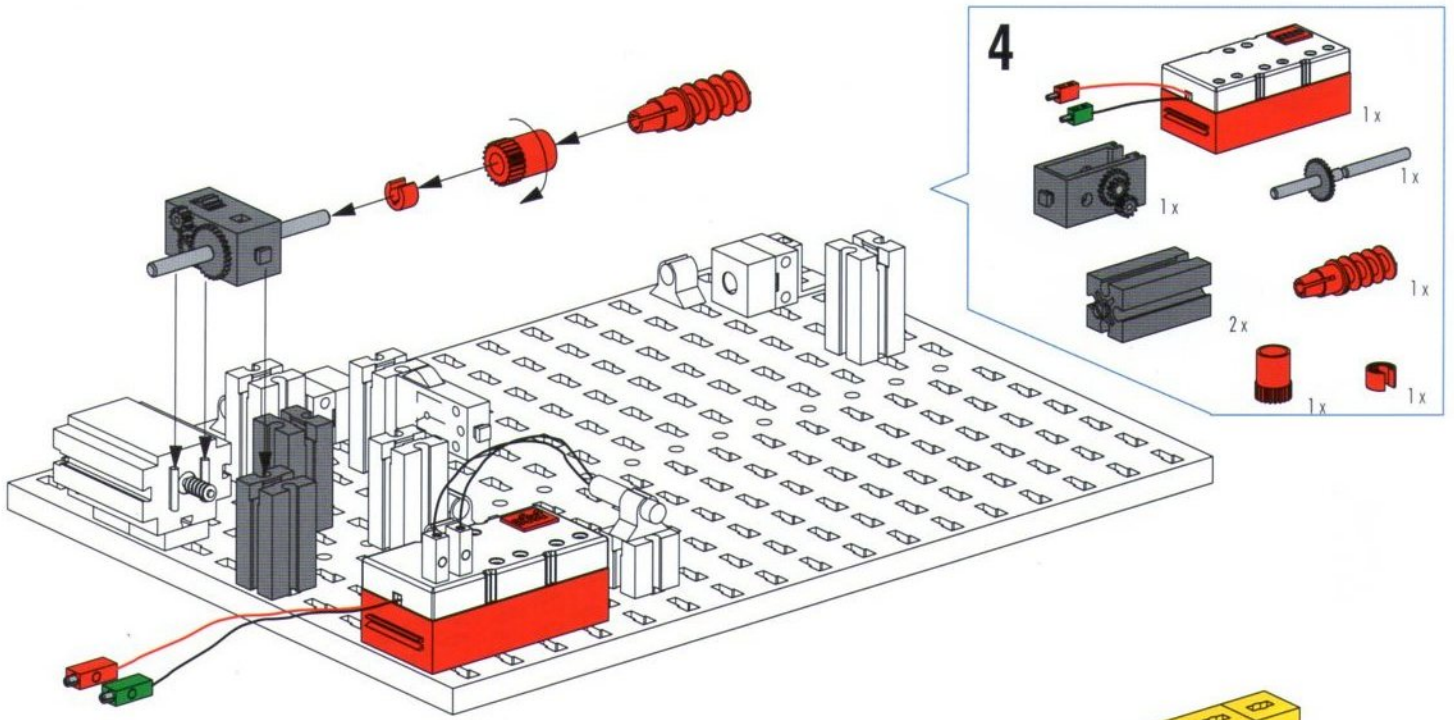

7



1x



1x



2x



1x



1x



2x

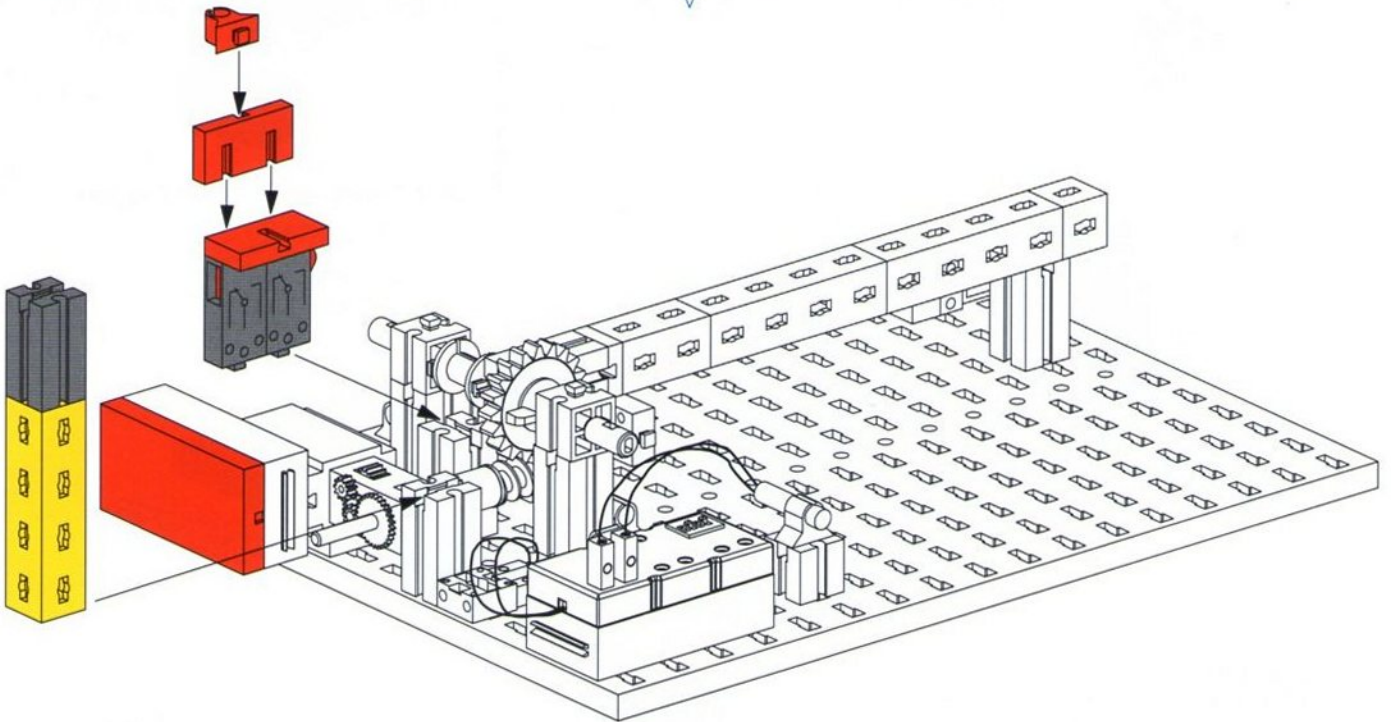

8



1x



1x



1x



1x



2x

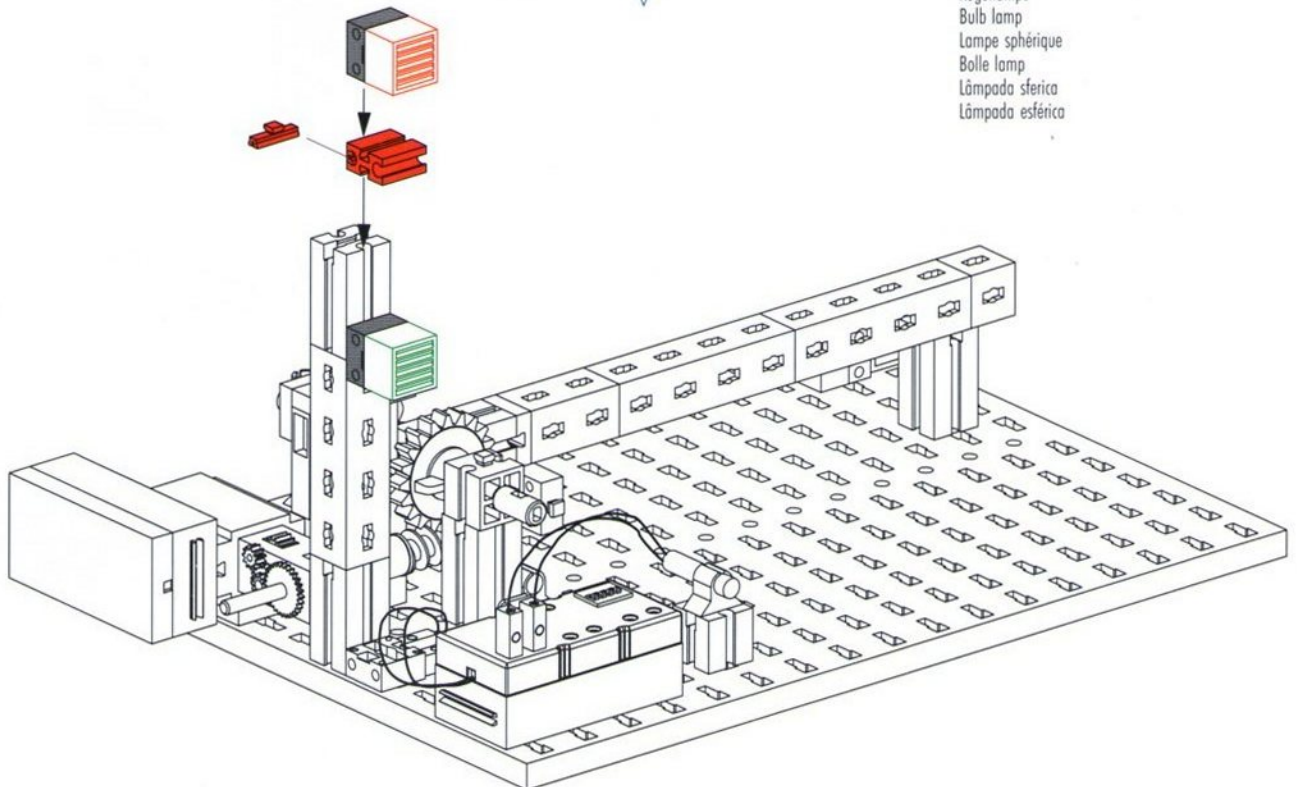

Kugellampe  
 Bulb lamp  
 Lampe sphérique  
 Bolle lamp  
 Lâmpada sferica  
 Lâmpada esférica





Bausteinspender  
 Brick dispenser  
 Distributeur d'éléments de construction

Bouwsteenautomaat  
 Dispensador de elementos  
 Distribuidor do componente

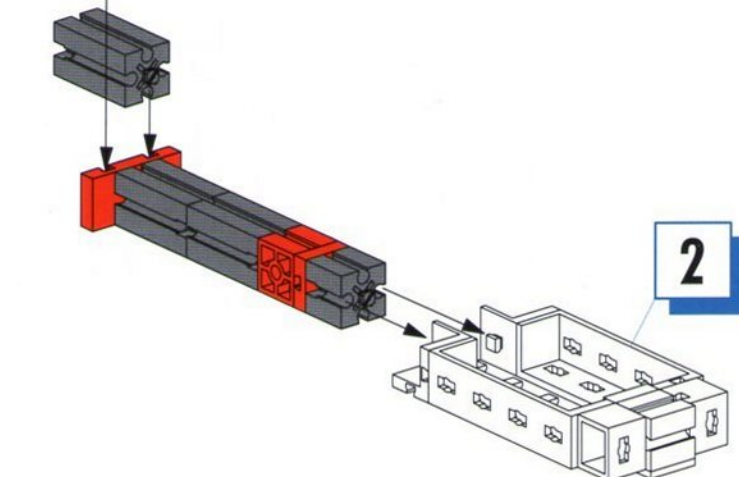
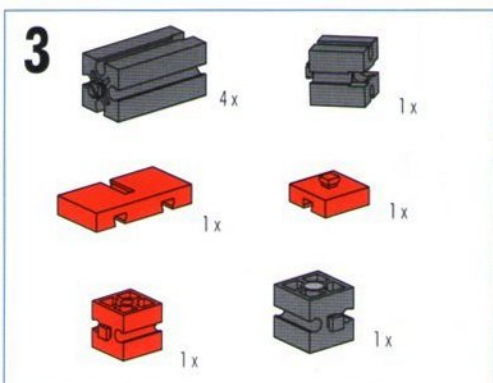
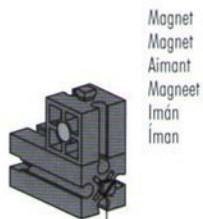
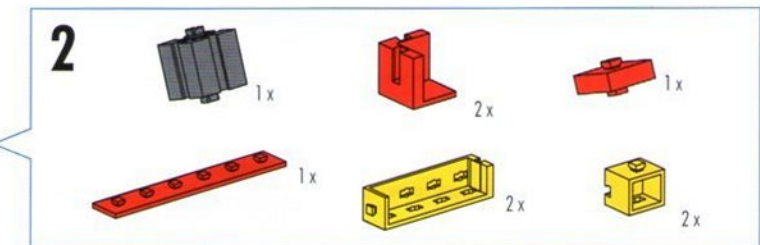
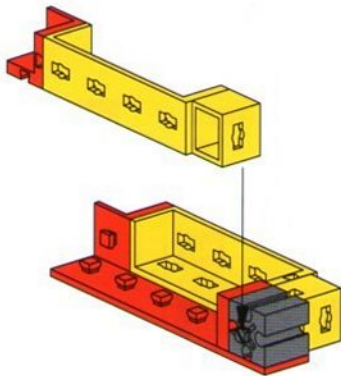
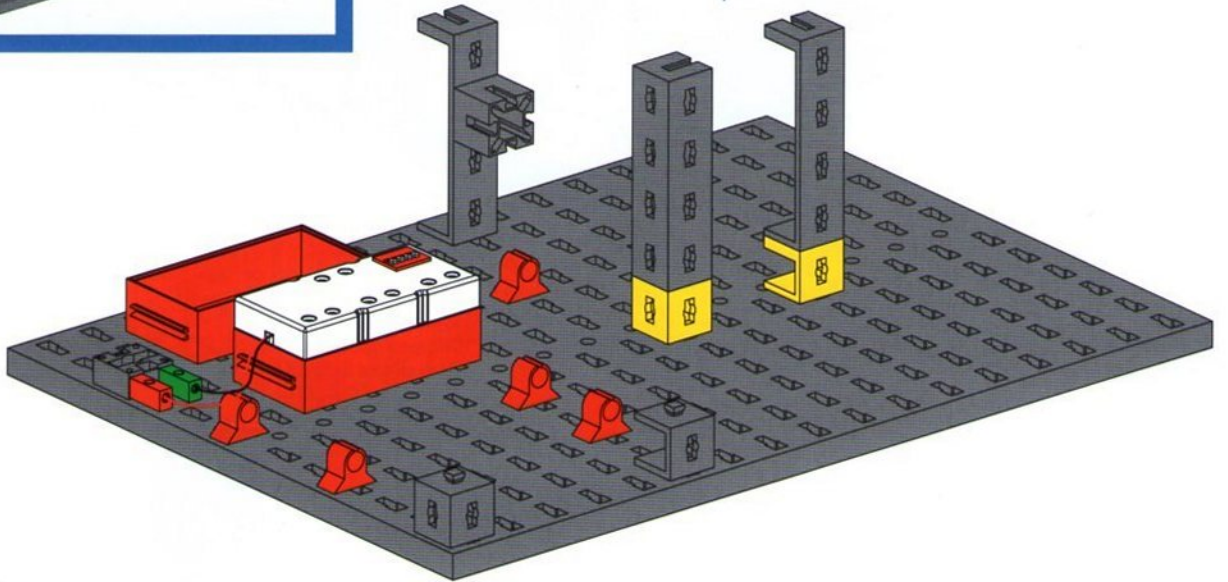
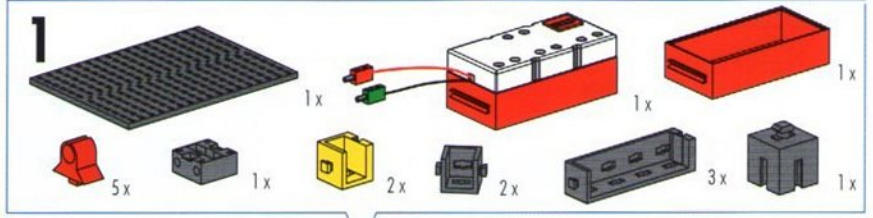



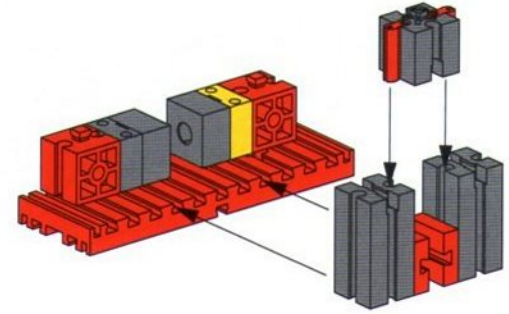
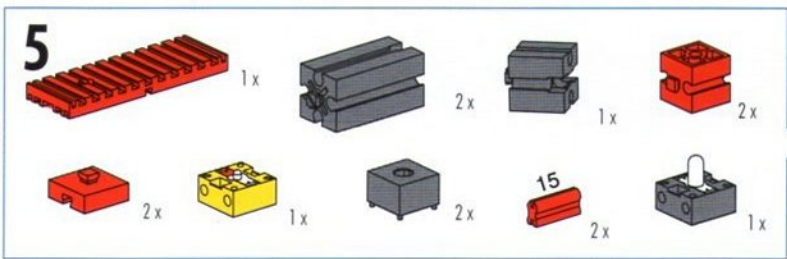
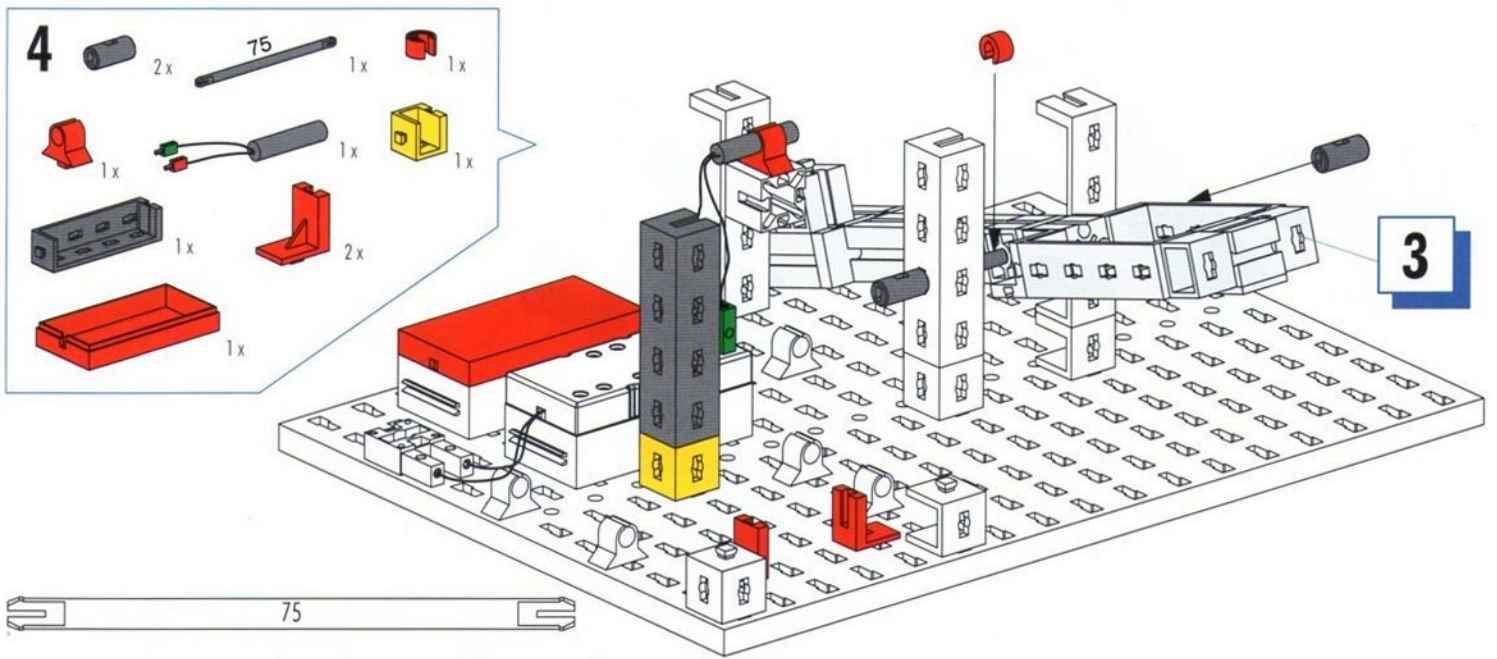

Kugellampe  
 Bulb lamp  
 Lampe sphérique  
 Bolle lamp  
 Lâmpada sferica  
 Lâmpada esférica

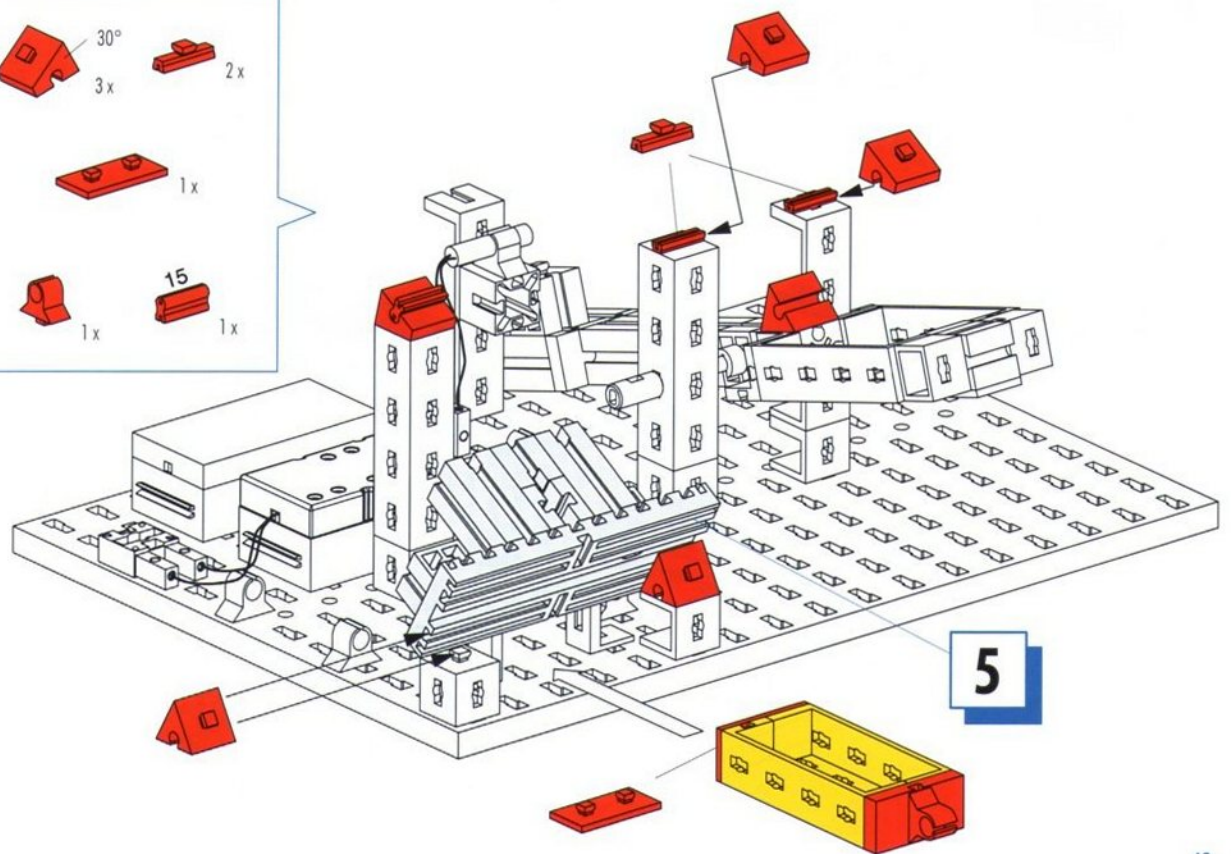
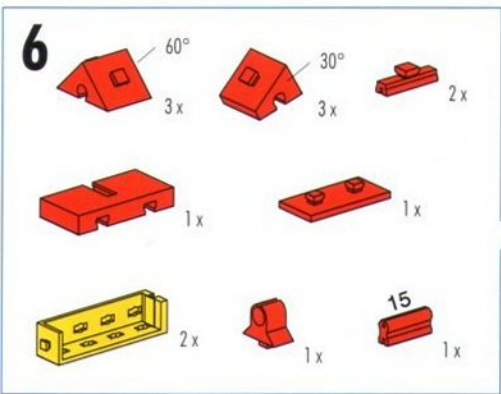



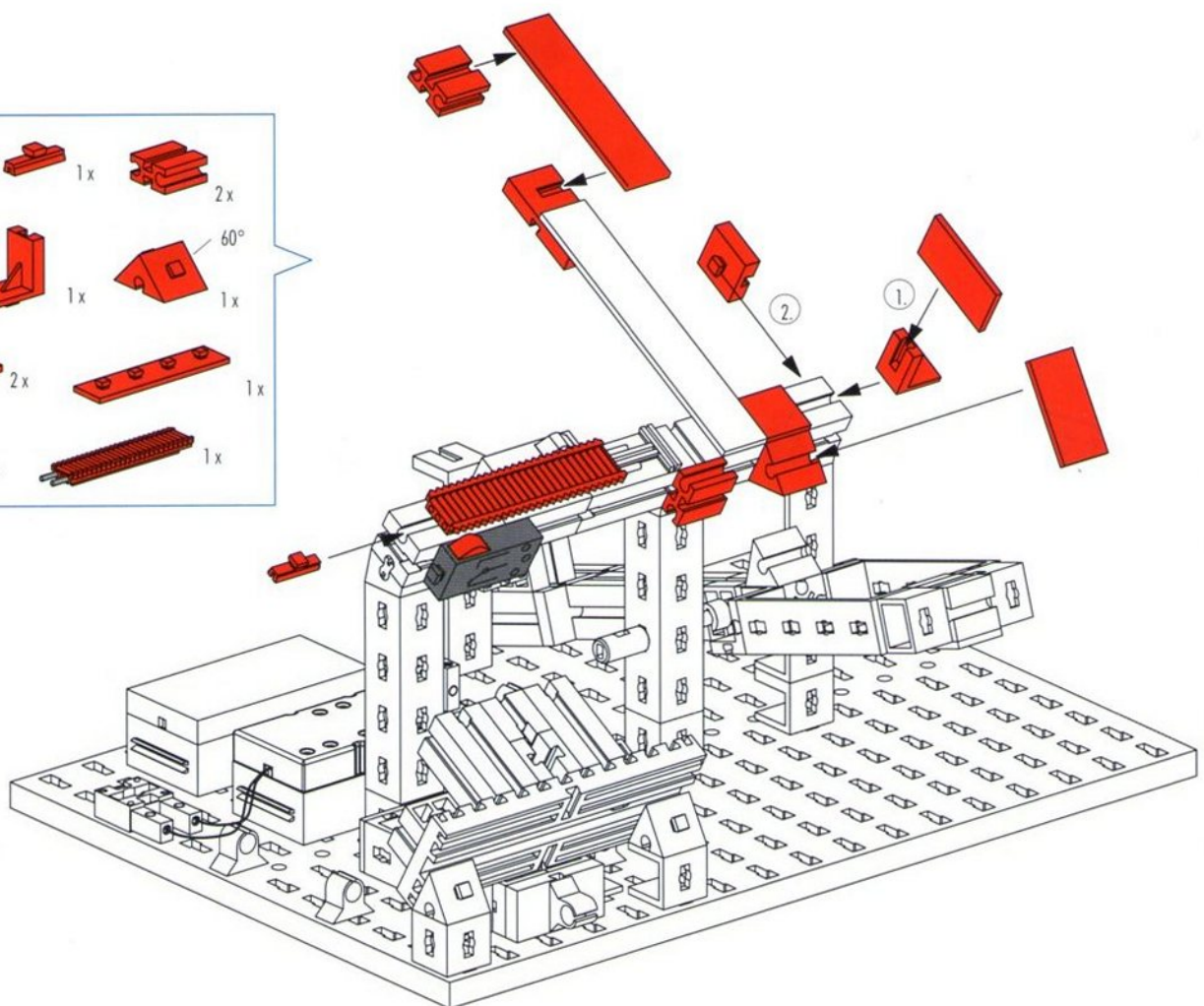
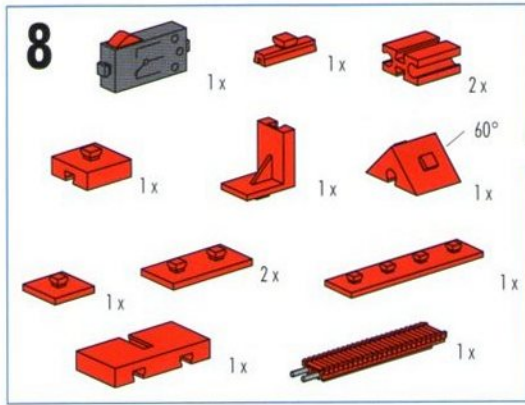
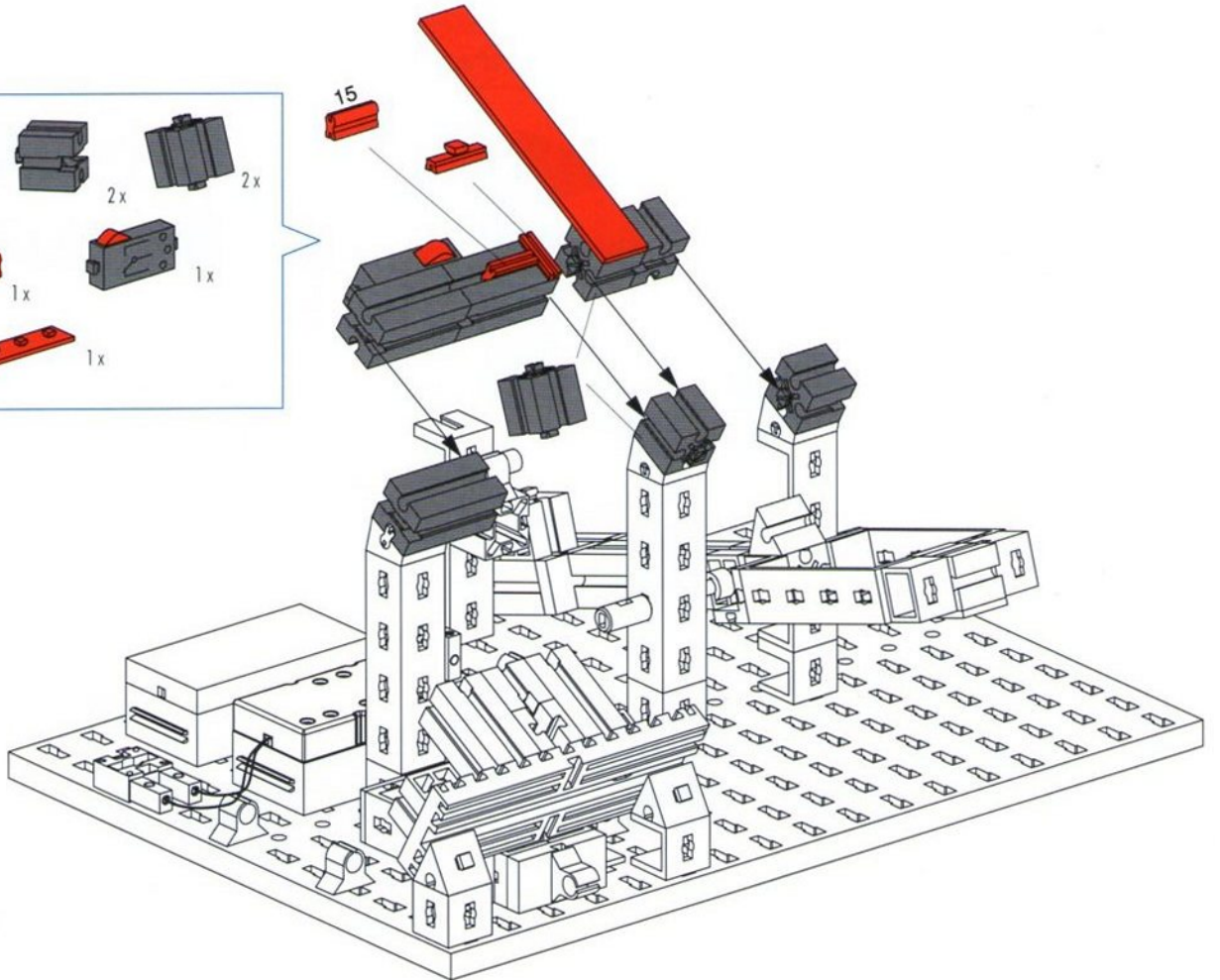
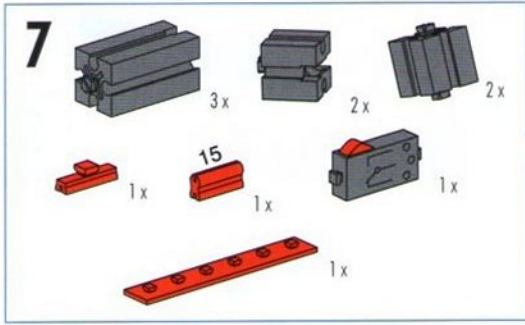



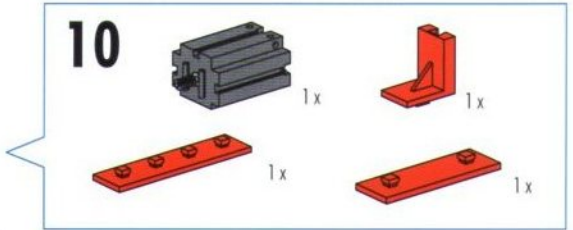
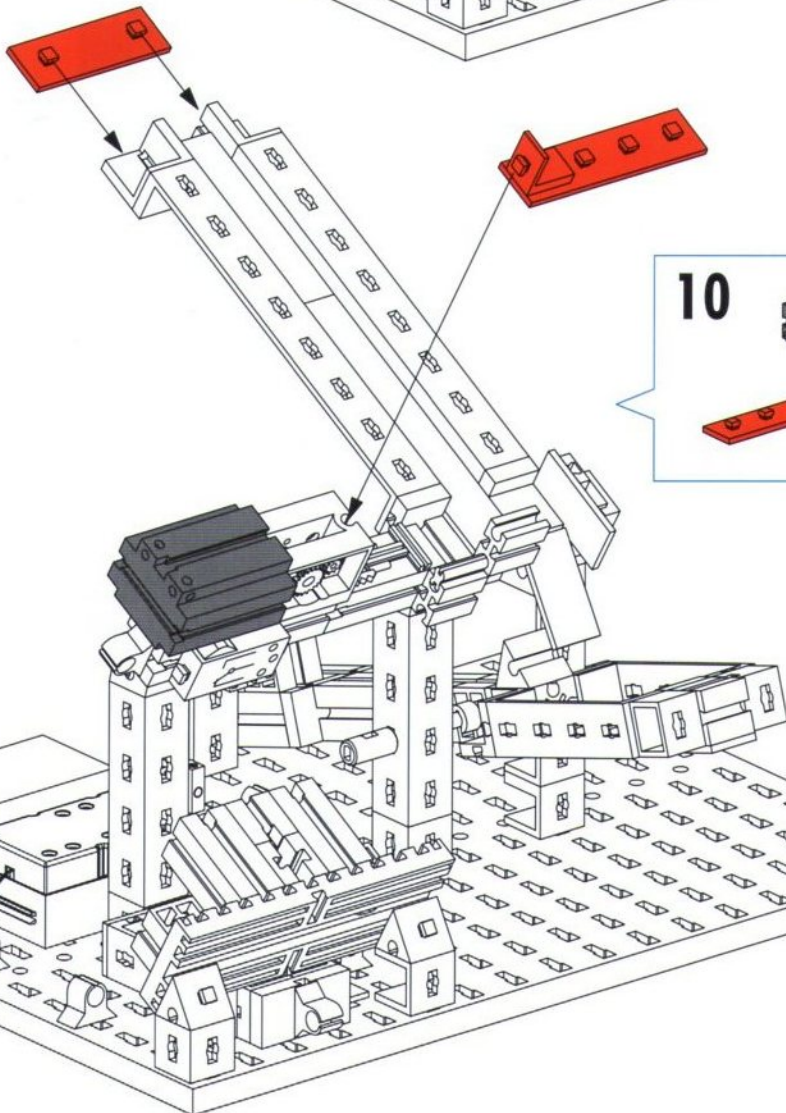
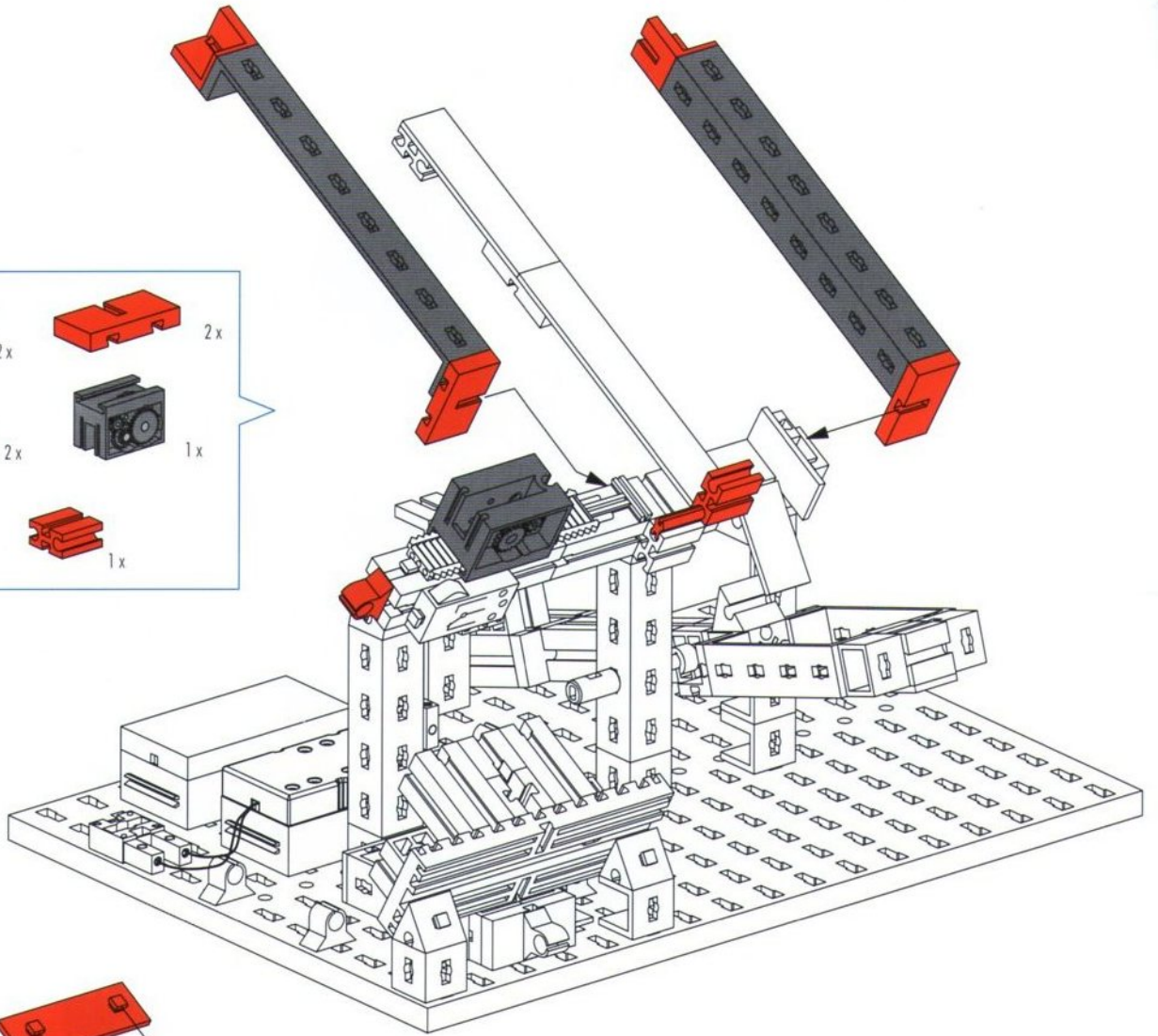
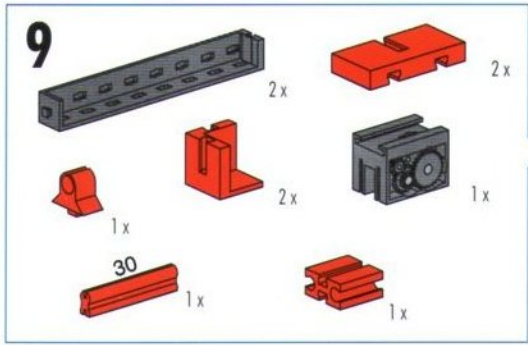

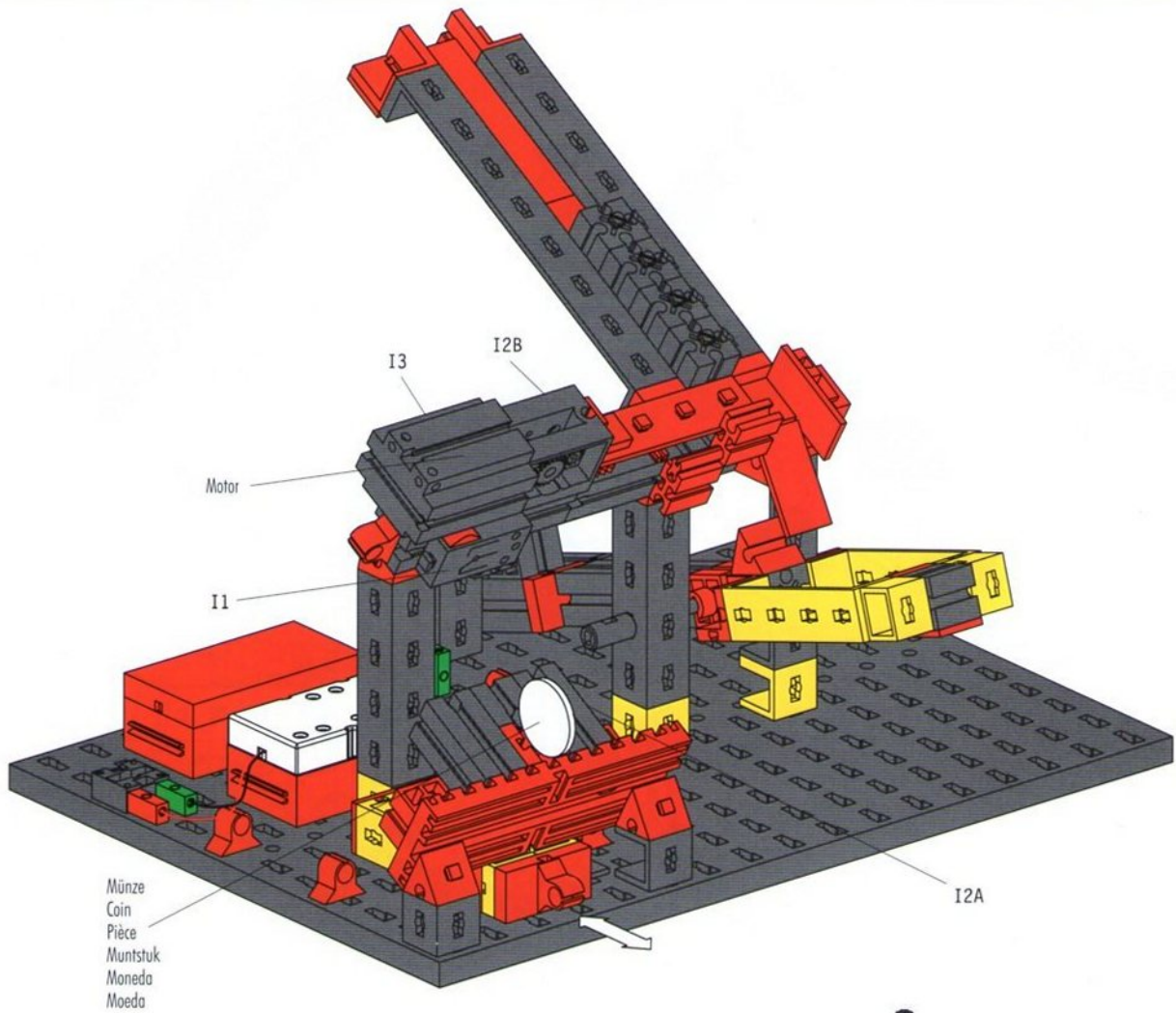

Schaltplan  
Circuit diagram  
Plan électrique

Schakelschema  
Diagrama de circuitos  
Plano elétrico de ligação

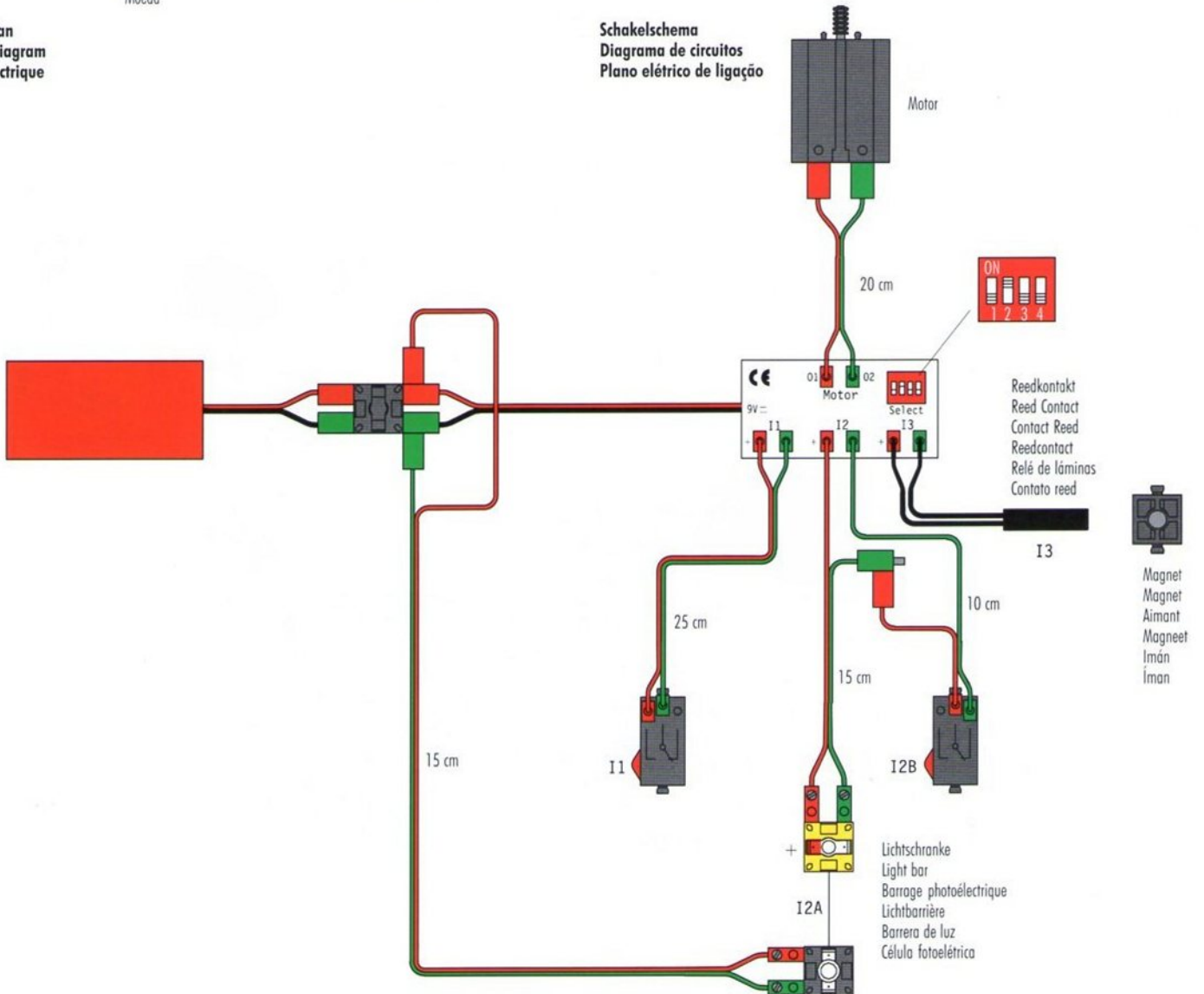



# PROFI E-Tec

**12**  
models



fischerwerke  
Artur Fischer GmbH & Co. KG  
Weinhalde 14-18  
D-72178 Waldachtal  
Telefon: 0 74 43/12-43 69  
Fax: 0 74 43/12-45 91  
email: [info@fischartechnik.de](mailto:info@fischartechnik.de)  
<http://www.fischartechnik.de>

10 89 35 • KW • 10/03 • Printed in Germany • Technische Änderungen vorbehalten • Subject to technical modifications

**fischartechnik** 